

**DRAGON
FIRE**

DF32, DF40 Grills



www.DragonFireGrills.com

ProFire

Read all instructions before you operate your grill. Save these instructions!



DANGER

If you smell gas:

- Shut off gas to the appliance.
- Extinguish any open flame.
- Open lid
- If odor continues, keep away from the appliance and immediately call your gas supplier or your fire department.



WARNING

- Do not store or use gasoline or other flammable vapors and liquids in the vicinity of this or any other appliance.
- An LP cylinder not connected for use shall not be stored in the vicinity of this or any other appliance.

If the information in this manual is not followed exactly, a fire or explosion may result causing property damage, personal injury or loss of life.

ATTENTION:

INSTALLER:

Please leave these instructions with the consumer.

CONSUMER:

Please read & retain these instructions for future reference and before installing or operating



CONTACT INFORMATION

For customer service, please contact your authorized dealer immediately.

If you need additional information and/or assistance, please contact:

ProFire Grills | 5565 N 124th Street, Butler, WI 53007

Toll-Free: 1-888-781-4657 | Fax: 1-888-781-3965

Safety Instructions

Placement and Location	4
Set-Up.....	4
Operation.....	4
Maintenance and Repair.....	5
Storage.....	5
Precautions Regarding Children.....	5

Proper Location of the Grill

Ensuring Proper Ventilation	6
-----------------------------------	---

Built-in Construction

Construction Materials.....	7
Built-in Dimensions	8
Enclosure Ventilation.....	9

Gas and Electrical Supply Requirements

Gas Requirements	10
Electrical Supply Requirements.....	11

Installation and Connection

Connecting the Grill.....	12
Leak Testing Procedure.....	14

Using Your Grill

Basic Grill Operation.....	15
Gas Cylinder Orientation	15
Grill Controls.....	16
Lighting the Burners	17
Proper Burner Flame.....	18

Cleaning and Maintenance

Stainless Steel Care and Cleaning.....	19
Rust Removal.....	20
Cleaning the Interior of Your Grill	20
Covering Your Grill.....	21
Seasonal Cleaning.....	21
Light Bulb Replacement.....	23

Appendix

Troubleshooting.....	24
Converting from LP to NG	26
Converting from NG to LG.....	29
Wiring Diagram.....	32
DF32 Dimensions	34
DF40 Dimensions	35
DF32 Replacement Parts.....	36
DF40 Replacement Parts.....	39
Limited Warranty	42

SAFETY INSTRUCTIONS

WARNING: Improper installation, adjustment, alteration, service or maintenance can cause injury or property damage. Read the installation, operating and maintenance instructions thoroughly before installing or servicing this equipment.

Placement and Location

- **Dragon Fire grills are designed for outdoor use only.**
- Never locate this appliance in an enclosed room, under a sealed overhead structure, or in any type of enclosed area such as a garage, shed, or breezeway. Keep clear of trees and shrubs.
- Do not place this grill under or near windows or vents that can be opened into your home.
- Dragon Fire grills are not intended for installation in or on recreational vehicles or boats.
- Maintain sufficient distance as to not overheat any overhead combustible material such as a patio cover.
- The area surrounding your new grill should be kept clean and free from flammable liquids and other combustible materials such as mops, rags or brooms, as well as solvents, cleaning fluids, and gasoline.
- Do not use the grill, grill cabinet, or area surrounding the grill as a storage area for flammable or plastic items. Do not store the liquid propane (LP) cylinder in the vicinity of this or any other appliance when it is not being used.

Set-Up

- Before installing built in grills in enclosures, copy all product information such as model number, serial number and type of grill (e.g., natural gas or LP) and store information in a safe place. This information is located on a plate located behind the grill on the left side of the chassis and is visible when grill is not in the cabinet or cart. There is an area on the back cover of this manual where you can write down this information.
- We recommend that a licensed contractor install your Dragon Fire grill. Installation must conform to local codes, or in the absence of local codes, with either the National Fuel Gas Code, ANSI Z223.1 / NFPA54, Natural Gas and Propane Installation Code, CSA B149.1, or Propane Storage and Handling Code, B149.2), as applicable.

- Your Dragon Fire grill must be plugged into a permanent, grounded 110V outlet with a dedicated 15A GFCI breaker in accordance with local codes or the National Electrical Code, ANSI / NFPA 70, or the Canadian Electrical Code, CSA C22.1.
- Do not use an extension cord to supply power to your Dragon Fire grill. Such use may result in fire, electrical shock or other personal injury. Do not install a fuse in the neutral or ground circuit. A fuse in the neutral or ground circuit may result in an electrical shock hazard. Do not ground this appliance to a gas supply pipe or hot water pipe. Keep any electrical supply cords and the fuel supply hose away from any heated surfaces.
- To prevent fire and smoke damage, remove all packaging material before operating grill.
- Before you start cooking, clean the entire grill thoroughly with hot, soapy water. This is necessary to remove residual solvents, oil and grease used in the manufacturing process. The grates should also be thoroughly cleaned in the same manner.

Operation

- Burners must be aligned with the valve orifice and seated in the bracket slot. Failure to do so could result in a fire and injury.
- Do not use grill for other than intended use.
- In the event that a burner goes out, turn burner knobs to the full OFF position, fully open the grill hood and let it air out. Do not attempt to use the grill until the gas has had time to dissipate.
- Never use the grill if the drip pan is not properly installed. Drip pan should be pushed all the way to the rack located just under the grill. Fire or explosion can result from an improperly installed drip pan.
- Keep all electrical supply cords and the rotisserie motor cord away from the heated areas of the grill.

 **California Proposition 65 Warning:** This product can expose you to chemicals including Chromium (hexavalent compounds), which are known to the State of California to cause cancer and birth defects or other reproductive harm. For more information go to: www.P65Warnings.ca.gov.

- Never use the grill or side burner in windy conditions. If used in a consistently windy area a windbreak will be required. Always adhere to the specified clearances listed in this manual.
- Never line the grill or side burners with aluminum foil.
- When the unit is not in use, be sure to turn off the gas at the LP tank.
- Do not install or operate your grill unit in such a manner that the cross ventilation openings are blocked. Fresh air must be able to pass through installed vents to safeguard against residual gas accumulation. Failure to allow proper ventilation may cause fire or explosion.
- When handling LP gas line and connectors, do not allow them to come in contact with any metal surfaces of the cabinet. Do not drop LP connectors.
- Do not use fuel such as charcoal briquettes in gas grills.
- Gas sources to the grill and side burners must be regulated. Do not operate grill or side burners if regulators have been removed, fire or explosion can occur.
- Never leave the grill and side burners unattended when in use. When using pots and pans, boil-overs will cause smoking and greasy boil-overs may ignite.
- Always use the proper size pan. Select utensils with flat bottoms large enough to cover the burner. The use of under-sized utensils exposes the sides of the utensils to direct contact with a portion of the flame. This can scorch utensils and hamper cleanup. Excessive flames on large stainless steel pots can result in permanent discoloration. For best results, we recommend commercial quality aluminum pans and utensils.
- Always position handles of utensils so they do not extend over adjacent work areas or cooking areas. This reduces the risk of burns, ignition of flammable materials, and spillage due to accidental contact with the utensils.
- Do not use water on grease fires. Never pick up a flaming pan. Turn the appliance off and smother the flaming pan with a tight-fitting lid, a cookie sheet or a flat tray. For flaming grease outside of the pan, smother it with baking soda or use a dry chemical or foam-type fire extinguisher.
- Never allow clothing, pot holders or other flammable materials come in contact with or be close to any grate, burner or hot surface until it has fully cooled. Never wear loose fitting or hanging garments while using your grill. Fabric may ignite and result in personal injury.
- When using the grill, do not touch the grill rack, burner grate, or immediate surroundings as these areas become extremely hot and can cause burns. Use handles or knobs.
- Only use dry pot holders and do not use a towel or other bulky cloth in place of pot holders. Moist or damp pot holders used on hot surfaces can cause burns.
- Do not heat any unopened glass or metal container of food on the grill. Pressure may build up and cause the container to burst, possibly resulting in serious personal injury or damage to the grill.
- Do not reach over your grill or any other surfaces when hot or in use.

Maintenance & Repair

- Spiders and other insects can nest in the burners of the grill and block the gas and airflow to the burner ports. This creates a dangerous condition that can result in a fire behind the valve panel. Inspect and clean the burners periodically and follow the guidelines in the Cleaning and Maintenance section of this manual.
- Unless specifically recommended in this manual, do not repair or replace any part of the grill. A qualified technician should perform all service. Any repairs made by a non-Dragon Fire approved dealer technician will void your warranty.

Storage

- When your gas grill is not in use, turn off the gas at the supply cylinder.
- Storage of a grill indoors is permissible only if the supply cylinder is disconnected and removed.

Precautions Regarding Children

- Never leave children unattended in the area where the grill is being used. Close supervision of children is necessary when any appliance is used near children.
- Do not store items of interest to children around or below the grill.
- Never allow children to sit or stand on any part of the grill.

PROPER LOCATION OF THE GRILL

Here are some general considerations when determining where to place your new barbecue island. Be certain that your installation will meet all city and local safety codes and requirements.

When planning your Dragon Fire grill location, access to gas lines and 120V power supplies should be considered. If you are using natural gas, the location with the shortest gas line run is recommended. You may need a grounded, dedicated, 15A 120V GFCI power source for use of your appliances (e.g., lights, rotisserie, refrigerator, receptacles, etc.).

When determining a suitable location, consider factors such as exposure to wind, proximity to traffic paths, and windows that open into the home.

Locate the grill enclosure any place where there is adequate ventilation. The size and configuration of your house and yard will determine how you should locate your grill enclosure, but as a general rule, do not place it under or near windows that can be opened into your home. Ventilation is addressed in greater detail in the next section.

The sides, bottom and back of the grill enclosure should not be any closer than 16" to combustible construction.

To reduce the risk of personal injury caused by reaching over a hot appliance, avoid locating cabinet storage space directly above the outdoor grill.

Dragon Fire grills are designed for outdoor use only. Under no circumstances is this appliance to be used indoors including garages or any other enclosed area.



Carbon Monoxide Hazard

This appliance can produce carbon monoxide which has no odor.

Using it in an enclosed space can kill you.

Never use this appliance in an enclosed space such as a camper, tent, car, or home.



Ensuring Proper Ventilation

Do not locate your barbecue island in an enclosed area, which is any covered area that is walled on two, three, or four sides. This includes areas or rooms such as a garage, shed, breezeway, patio, cabana, etc.

Although some enclosed areas may have windows, screens, or ventilation systems, they are nevertheless considered to be hazardous and may cause damage, injury, or death. Enclosed areas are NOT approved for a barbecue island.

Do not locate your barbecue island under a sealed overhead structure.

- **Solid foundation**
- **Open on three sides**
- **No overhead combustible surfaces**
- **Not placed near windows**
- **No overhead storage**
- **No combustible materials stored nearby**

Note: The terms “built-in construction” and “grill enclosure” as used in these instructions refer to any method for installing a barbecue island for use. A barbecue island is both built-in constructions and a grill enclosure. Read these instruction before constructing your grill enclosure. We strongly recommend that grill owners hire a contractor to construct the built-in enclosure.

Failure to follow these instructions may result in voiding your warranty, property damage, injury or death.

Clearances

- Minimum clearance from sides and back of unit to adjacent combustible construction below top of unit, 16" from sides and back.
- Minimum horizontal clearance from sides and back of unit to adjacent vertical combustible construction extending above top of unit, sides and back.
- Do not locate this appliance under overhead unprotected combustible surfaces.
Only for installation in a built-in enclosure constructed of non-combustible materials.

Construction Materials

ProFire will not be held responsible for property damage, injury, or death as a result of locating a grill enclosure in a non-approved location or using non-approved construction materials.

DO NOT use combustible materials for the built-in construction. Grill must be installed in a non-combustible enclosure only.



Acceptable building materials

Brick, cinder block, steel frame, hardboard, granite, tile, glass brick, concrete, cement, stucco, stone.



Unacceptable building materials

Wood of any sort, laminate or synthetic materials, plastics, linoleum, fiberglass.

In addition, we do not recommend using materials that are susceptible to damage or decomposition by weather, such as dry wall or plaster. We strongly recommend that grill owners hire a contractor to construct the built-in enclosure.

Failure to follow these instructions may result in voiding your warranty, property damage, injury or death.

BUILT-IN CONSTRUCTION *continued*

Built-in Dimensions

Plan the installation so that the electrical connection, gas shut-off valve, and pressure regulator are accessible inside the base enclosure. The gas valve shall be readily accessible for hand operation. A door on the enclosure to gain access to the gas valve is acceptable, provided it is non-locking and can be opened without the use of tools.

The design of the outdoor cooking enclosure must allow the LP gas cylinder to be connected and disconnected and the connections inspected and tested.

There must be a minimum clearance of 2 inches (51mm) between the floor of the LP-gas cylinder enclosure and the ground.

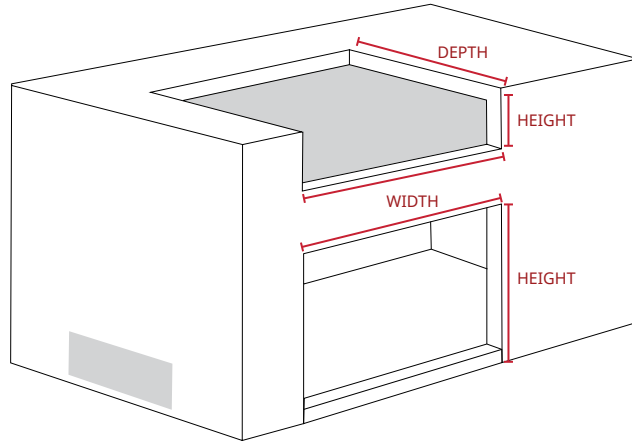

The cut out dimensions shown below are for Dragon Fire appliances only.

Model	Description	Width	Depth	Height
DF32	Dragon Fire 32" Grill	30-1/2"	23-1/4"	8-1/2"
DF40	Dragon Fire 40" Grill	37-1/2"	23-1/4"	8-1/2"

Model	Description	Width	Height
PFDD	Large Double Doors	32-1/4"	16-1/4"
PFSMDD	Small Double Doors	27-1/4"	16-1/4"

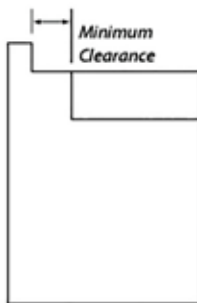

Side view of enclosure with back splash

The back edge of the grill must maintain a minimum clearance of 2" from non-combustible back splash materials.

Enclosure Ventilation

For proper ventilation, the base structure must be constructed using one of two designs:

DESIGN OPTION 1

An enclosure with one side open

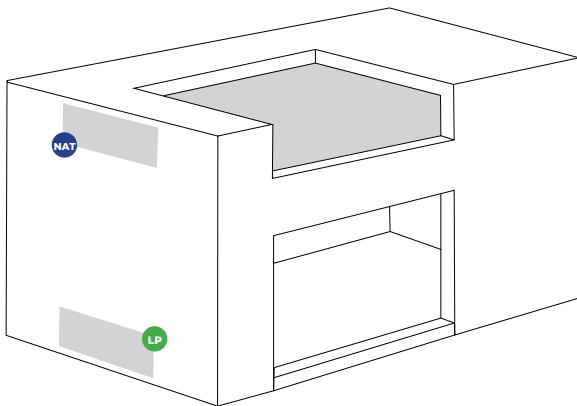

At least two ventilation openings at cylinder valve level shall be provided in the side wall, equally sized, spaced at 180 degrees and unobstructed.

Each opening shall have a total free area of not less than 10 square inches (254 square mm).

Ventilation openings shall be provided at floor level and shall have a total free area of not less than 10 square inches (254 square mm). If the ventilation openings at floor level are in a side wall, there shall be at least two openings.

DESIGN OPTION 2

An enclosure having four sides, a top, and bottom

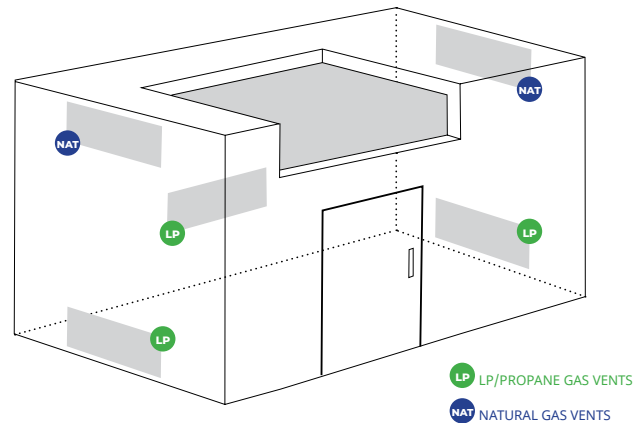

The bottom of the openings shall be at floor level and the upper edge no more than 5 inches (127mm) above the floor. The openings shall be equally sized, spaced, and unobstructed.

LP-gas cylinders should be ventilated by openings at the level of the cylinder valve and the floor level. The effectiveness of the openings, for purposes of ventilation, shall be determined with the LP-gas supply cylinder in place.

Why vent placement is important

LP/Propane Gas: LP gas is heavier than air and will settle to the lowest levels of an outdoor kitchen/island. It is very important to provide adequate cross ventilation around the areas where gas can accumulate in the lower levels of the structure. If the propane cylinder is located in the outdoor kitchen/island then both the appliance and the gas tank will need to be ventilated appropriately. See picture above for proper ventilation locations.

NG/Natural Gas: Natural gas is lighter than air and will rise to the highest levels of the outdoor kitchen/island. It is very important to provide adequate cross ventilation around the areas where gas can accumulate at these higher levels of the structure. See picture above shown for proper ventilation locations.

LIQUID PROPANE

Tank requirements

For plumbed-in LP installation, maximum line pressure for plumbed-in propane is 11" WC (3.5 kPa).

The grill must be used with the gas pressure regulator. The regulator will control and maintain a uniform gas pressure in the manifold. The burner orifices have been sized for the gas pressure delivered by the regulator.

WARNING: Attempting to operate the grill unit without the gas regulator installed could cause an explosion and possible death.

Cylinder Specification

The LP cylinder must be constructed and marked in accordance with the Specifications for LP-Gas Cylinders of the U.S. Department of Transportation or the National Standard of Canada, *CAN/CSA-B339, Cylinders, Spheres and Tubes for Transportation of Dangerous Goods; and Commission*, as applicable.

Any LP gas supply cylinder used with this grill must be approximately 12 inches in diameter and 18 inches high.

The maximum fuel capacity is 20 lbs. of propane, or 5 gallons. Full cylinder weight should be approximately 38 lbs. (43.7 lbs. nominal water capacity.) Never fill the cylinder beyond 80% full.

Tank must be equipped with a listed overflow protection valve and must have a collar to protect the valve. Turn tank valve off when grill is not in use.

Transporting and Storing LP Gas

Transport only one cylinder at a time. Ensure the cylinder is secured in an upright position with the control valve turned off and the dust cap in place. Store cylinders outdoors and out of reach of children. Do not store cylinders in a building, garage, or any other enclosed area.

Place the dust cap on the cylinder valve outlet whenever the cylinder is not in use. Only install the type of dust cap on the cylinder valve outlet that is provided with the cylinder valve. Other types of caps or plugs may result in leakage of propane.

NATURAL GAS

NG Service Installation and Connection

Natural gas installation of this appliance must conform with local codes or, in the absence of local codes, to the national fuel gas code, ANSI Z223.1a-1998. Installation in Canada must be in accordance with the standard CAN/CGA-B149.2, Propane Installation Code.

You do not need to hire a contractor to install your natural gas service, but you need to make sure you have all required permits and ensure the installation complies with State and local code. We recommend you hire a certified contractor if you do not wish to do the installation yourself.

The natural gas pipe from your house to the location of your barbecue island needs to be $\frac{3}{4}$ " and terminate with a shut-off valve with a $\frac{1}{2}$ " male fitting. Check with a contractor or your local inspector for requirements.

Always check the rating plate to make sure the gas supply you are hooking up to is the gas type the grill is manufactured for.

NG Regulator

The grill for use with natural gas comes equipped with its own regulator that **MUST NOT** be removed. If this regulator needs to be replaced, use only the type specified by for this appliance.

IMPORTANT: Never connect the grill to an unregulated gas supply.

Shut-off Valve

Ensure that the service supplying the grill is fitted with a shut off valve conveniently positioned near the grill and giving ease of access.

The grill must be isolated from the gas supply piping system by closing its individual manual shutoff valve during any pressure testing of the gas supply piping system at test pressures equal to or less than 0.5 psi (3.5 kPa).

ELECTRICAL SUPPLY REQUIREMENTS

You will need a dedicated 120V 15 amp grounded electrical service. The power supplied to your grill enclosure must be on a dedicated circuit with no other appliances or lights sharing the power.

You do not need to hire a contractor to install your electrical service, but you must ensure you have all required permits and the installation complies with State and local code. We recommend you hire a certified contractor if you do not wish to do the installation yourself.

If your dealer is not a certified contractor, you will need to hire a contractor for installation of your electrical service.

When installed in the United States, the electrical wiring must meet the requirements of National Electric Code, ANSI/NFPA 70-1999 and any applicable state or local codes. The electrical circuit must be installed by an electrical contractor and approved by a local building / electrical inspector.

To determine the current, voltage, and wire size required for the island configuration to be connected, refer to the following:

- Wire size is determined by length of run from breaker box to the barbecue island and maximum current draw.
- We recommend copper wire with THHN insulation.
- All wiring must be copper to ensure adequate connections. Do not use aluminum wire.
- When NEC requires the use of wires larger than #6 (10mm²), install a junction box near the barbecue island and use #6 (10mm²) wire between the junction box and the grill enclosure.

INSTALLATION AND CONNECTION

CONNECTING THE GRILL

These instructions show you how to connect this grill.

If you plan to convert to your grill from LP to NG, you need to do this before it is connected to a gas source. Grill conversion instructions can be found on page 26 and ordering information can be found in this manual on page 36. There are a few differences between connecting to LP and NG.

1. Place the Grill in the Cut-Outs

You will need a second person to help you to avoid damaging the grill, the transformer, or your barbecue island .

Before installing a grill in any island or cut out, make sure that the opening is not bigger than the outside frame of the grill unit. Refer to the correct cut out dimensions on page 8. The grill should rest on the lip of the frame. For drop-in accessories, adequate cross ventilation must be designed into enclosure to ensure the drop-in grill or side burner does not become overheated.

Pay careful attention to the location of gas lines. Gas lines should be routed away from sources of heat and should make as few bends as possible.

Check to see if gas line connections will be accessible when grill is installed.

- If gas line connections are not easily accessible when the grill is installed, support the grill above counter level and attach the gas lines to the grill. When the gas connections are made, slide the grill into the cut out.
- If gas line connections are accessible when the grill is installed, slide the grill into the cut out and then attach the gas lines.



Be very careful not to kink gas lines when lowering the grill into the cut out.

Keep your fingers away from where the grill will be supported on counter. Your fingers could become trapped and serious injury could occur.

Check to make sure the grill is level and is supported around the entire outside edge. If the grill is not level or is unstable, use non-combustible shims under the outside lip to stabilize it.

Perform the leak test procedure as described earlier in this manual.

2. Connect the Gas Line to the Grill

Note: Make sure you have converted the grill for natural gas before connecting the gas line to the regulator. See page 26 for instructions on converting the grill from LP to NG.

Connecting the grill only

Slide the grill forward about six inches and connect the gas line to the grill using the appropriate connection for your gas type.



LIQUID PROPANE



NATURAL GAS



INSTALLATION AND CONNECTION *continued*

3. Connect the a Gas Source

Liquid Propane Connection

Use the pressure regulator and hose assembly supplied with the grill, or a regulator and hose assembly with the same specifications. Replacement LP regulator and hose must have a coupling nut that will connect to a QCC-1 cylinder valve on one end and a female fitting that will connect to a 3/8" tapered fitting on the grill manifold. See the figures below.

Connect the brass fitting to the manifold behind the grill. Do not use Teflon tape or plumber's dope. Do NOT remove the NG regulator from the manifold. Connect the coupling nut to the LP cylinder valve.

When you are finished connecting to the gas source, perform a leak test.

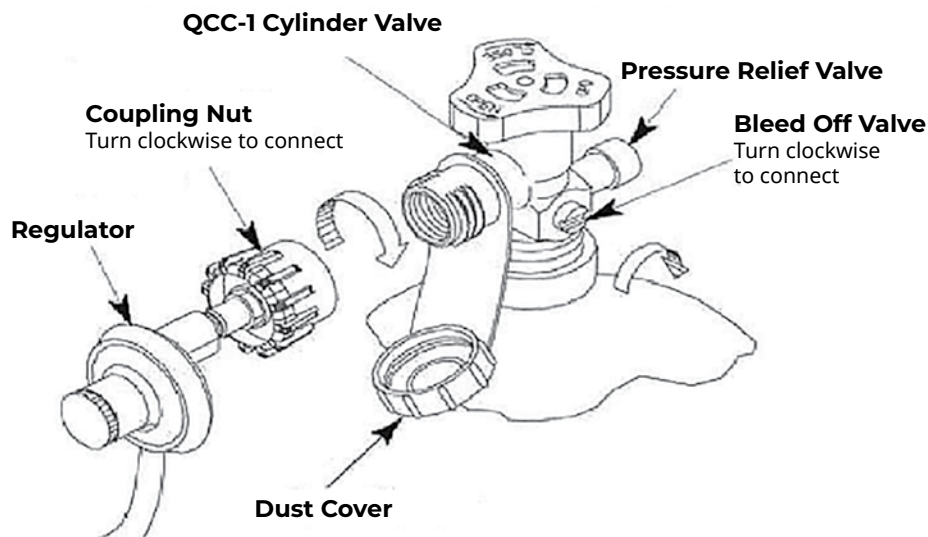

Natural Gas Connection

Connect the gas line to the NG stub-up inside the barbecue island.

When you are finished connecting to the gas source, perform a leak test.

Leak Testing Procedure

Perform a leak test at least once a year whether the gas supply cylinder has been disconnected or not. In addition, whenever the gas cylinder is connected to the regulator or whenever any part of the gas system is disconnected or replaced, perform a leak test.

As a safety precaution, remember to always leak test your grill outdoors in a well-ventilated area. Never smoke or permit sources of ignition in the area while doing a leak test. Do not use a flame, such as a lighted match to test for leaks. Use a solution of soapy water.

1. Prepare a leak testing solution of soapy water by mixing in a spray bottle one part liquid soap to one part water.
2. Make sure all the control knobs are in the OFF position.
3. Turn on the gas.
 - a. On **natural gas systems**, turn the main feed valve to the grill.
 - b. On **LP systems**, turn the cylinder valve knob counter clockwise one turn to open.

4. Apply the leak-testing solution by spraying it on joints of the gas delivery system. Blowing bubbles in the soap solution indicates that a leak is present.
5. Stop a leak by tightening the loose joint or by replacing the faulty part with a replacement part recommended by the manufacturer. Do not attempt to repair the cylinder valve if it is damaged. The cylinder must be replaced.
6. Turn all control knobs back to the full OFF position.

If you are unable to stop a leak:

1. Turn all control knobs back to the full OFF position.
2. Shut off the gas supply to the grill and release pressure in the hose and manifold by pushing in and turning any of the control valves one quarter turn counter-clockwise.
3. On LP systems, remove the cylinder from the grill.
4. Call an authorized gas appliance service technician or an LP gas dealer.

Do not use the appliance until the leak is corrected.

USING YOUR GRILL

READ ALL INSTRUCTIONS BEFORE YOU OPERATE YOUR GRILL

We recommend you wash your entire grill with soap and water prior to lighting it for the first time. Oils are used during the manufacturing process and some residual oil may still be on the stainless steel parts of your grill. Washing will reduce the possibility of discoloration. We also recommend you keep your grill covered when not in use. This will minimize the amount of dust and dirt that accumulates on your grill and extend the life of your grill.

Remember to use your Dragon Fire grill safely by following these reminders:

- It is dangerous to use barbecue grills and side burners in any manner other than for what it is designed for.
- Do not use charcoal in a gas grill or side burner.

- Do not heat sealed containers such as cans or jars on grills or side burners. Explosion may result resulting in injury or death. Any sealed container, such as a pressure cooker, must have a properly operating pressure relieve valve to minimize explosion hazard.
- Never put combustible material such as paper, cloth, or flammable liquids on your grill at any time. Do not use grill, side shelves, cabinets, or any area around grill to store flammable materials.
- Never operate main burners and rear infrared convection burners at the same time. Excessive grill temperatures will result.

BASIC GRILL OPERATION

Before lighting, make sure all burner controls are off. Do not attempt to light the burners if the smell of gas is present. Check the connection with a soap and water solution after attaching the hose. For LP units, make sure there is gas in the tank and it is sitting upright. For natural gas units, make sure the shut off valve is on.

1. Make sure the drip tray is in place.
2. Light the grill burners using the instructions on page 17.

3. Turn the control knob to HIGH and preheat the grill for 10 minutes. Close the top cover during the appliance preheat period.
4. Place the food on the grill and cook to desired completion. Adjust heat setting if necessary. You may set the control knob to any position between HIGH and LOW.
5. Allow the grill to cool and clean the drip tray after each use.

Do not leave the grill unattended while cooking.

GAS CYLINDER ORIENTATION

LP gas cylinder must be up oriented upright during operation for proper vapor withdrawal. Operating the grill with the cylinder on it side will allow liquid gas to flow into the regulator. Erratic gas flow will occur, resulting in possible flare-ups or explosion.



USING YOUR GRILL *continued*



Warning

NEVER cover the entire cooking or grill surface with griddles or pans. Overheating will occur and burners will not perform properly when combustion heat is trapped below the cooking surface.

CAUTION: NEVER spray water on a hot gas unit. This may damage porcelain or cast iron components.



Warning

NEVER cover slots, holes, or passages in the oven bottom or cover an entire rack with material such as aluminum foil. Doing so blocks air flow through the oven and may cause carbon monoxide poisoning.

Aluminum foil linings may trap heat causing a fire hazard.

GRILL CONTROLS

The controls shown below are for the DF32 and DF40 grills. Familiarize yourself with these controls before lighting your grill.

The push button ON/OFF switch controlling the interior halogen and LED knob lights is located on the control panel at the front right side.

DF32 Control Panel

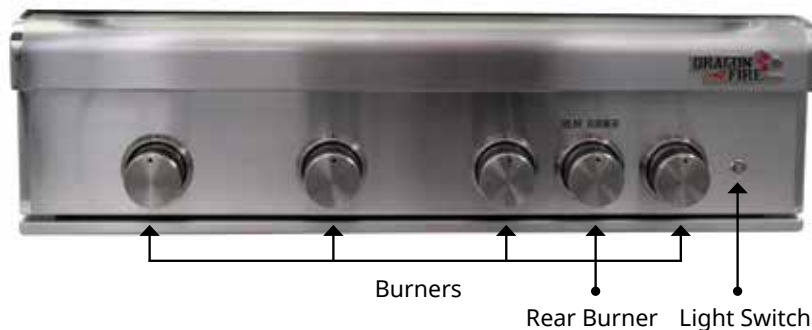

DF40 Control Panel

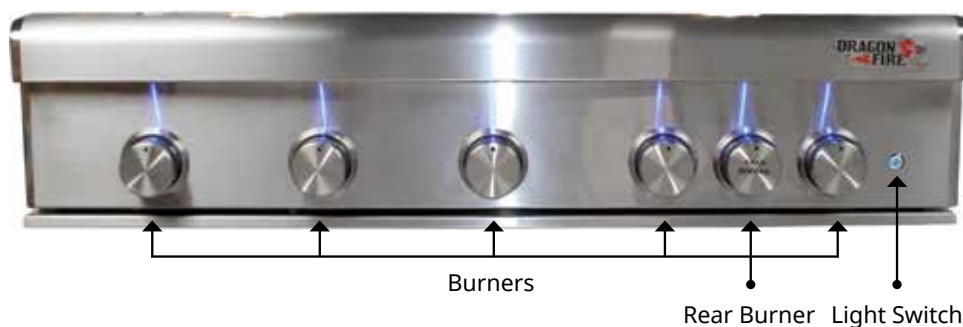

Close up image of a burner knob and light switch

LIGHTING THE BURNERS

Each time you light the grill, check the following:

- Inspect the hose before using the grill. If there is excessive abrasion or wear, or if the hose is cut, it must be replaced prior to using the grill. If you need a replacement hose, contact your Dragon Fire dealer.
- Ensure the area around the barbecue is clear of flammable substances such as gasoline, yard debris, wood, etc.
- Ensure there is no blockage of the airflow through the vent space located below the face of the unit.
- When using propane gas, keep the special ventilation openings in the enclosure free and clear of debris.
- If connected to a propane cylinder, carefully inspect the rubber hose attached to the regulator before each use.

Electronically Lighting the Burners

1. Open the hood.
2. Keep your face as far away from the burners as possible.
3. Press and rotate the burner knob counter clockwise past the light position to HIGH. You will hear a loud click as the electronic lighter produces a spark.
4. Listen for the sound of the gas igniting. If the burner does not light on the first try, repeat immediately.
5. If the burner does not light after three attempts, turn the control knobs to the OFF position. Wait five minutes until the gas clears before attempting to light it again.
6. Repeat the procedure or try the manual lighting procedure below.
7. Upon successful lighting, repeat the process on the other burners you wish to light.
8. To shut off the burners, rotate the knob and turn to OFF. It is normal to hear a popping sound when the burners are turned off.
9. You must wait 5 seconds before relighting any burner after it has been shut off.

- Ensure the propane cylinder, regulator, and rubber hose are installed in a location not subject to heating above 125° F (51° C).
- Ensure the burner flames burn evenly along both sides of each burner with a steady flame (mostly blue with yellow tipping). If burner flames are not normal, check the orifice and burner for insects or insect nests.
- Ensure the in-line gas valve or gas cylinder valve is always shut OFF when the barbecue is not in use.
- Do not operate the side burner with its cover closed or the back burner with its cover installed.

Manually Lighting the Burners

WARNING: Do not use standard matches or cigarette lighters to perform match lighting procedures. Serious burns can occur and lighters can explode.

1. Open the hood.
2. If you have just attempted to light the burner, allow five minutes for any accumulated gas to dissipate.
3. Slide out the drip tray from the grill.
4. Keep your face as far away from the burners as possible.
5. Light and insert a long stem match, holding it near the burner ports or use the match holder that was included with your Dragon Fire grill.
6. Push in and turn the control knob just past the LIGHT position to HIGH.
7. Listen for the sound of the gas igniting. If the burner does not light after five seconds, turn the control knobs to the OFF position. Wait five minutes until the gas clears before attempting to light it again.
8. If the burner does not light after several attempts see Troubleshooting Guide (page 24) in the back of this manual.

PROPER BURNER FLAME

Flame Color and Height

The burner flame has been set in the factory and should already be adjusted for proper height and intensity. Periodically, you may wish to check each burner's flame for color, height, and intensity. Remove the grill rack and the flame tamer over the burner you want to inspect.

When the burner is operating properly, the flame will appear between light to dark blue, with occasional yellow bursts (due to impurities in propane—this is normal).

When the burner is set on high, the flame spread out about ½" away from the side of the burner. (See Fig. 1)

When the burner is set on low, the flame should be just slightly visible when viewed from the side. (See Fig. 2)

Note: Flame that is mostly yellow or golden in color is often due to foreign matter in the burner. You may need to clean your burners. See page 22 for instruction on removing and cleaning your burners.



Fig. 1 *Burner set on high*

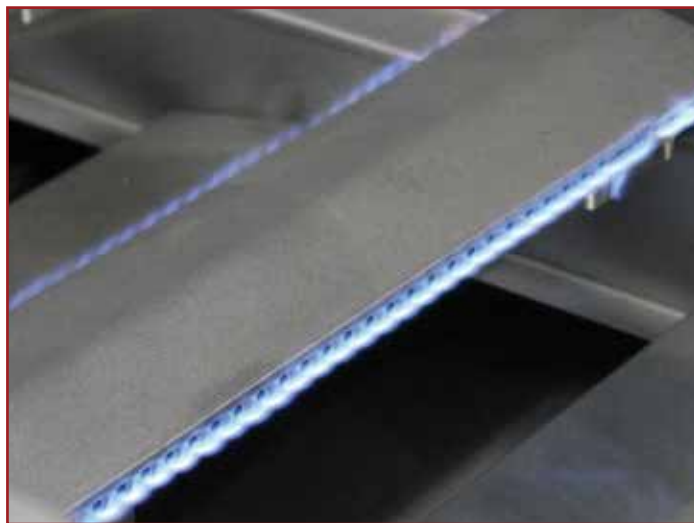

Fig. 2 *Burner set on low*



Warning

For proper operation, burners must be aligned with the valve orifice seated in the bracket slot. This is accomplished by first placing the burner tube shutter hole securely over the valve orifice and ensuring the male post on the rear of the burner rests in the opening in the grill chassis. Failure to do so could result in a fire and injury.

To ensure safe and proper maintenance, we recommend you follow these directions carefully.

Clean internal parts of the grill regularly as determined by the amount of use and foods cooked. The entire grill should be cleaned at least once a year.

In addition, keep the area around your grill clear and free from combustible materials, gasoline, and other flammable vapors and liquids. Do not obstruct the flow of combustion and ventilation air.

DISCONNECT ELECTRICAL SUPPLY BEFORE CLEANING ANY PART OF THE GRILL.

These instructions describe the best way to care for your stainless steel. They apply to grills and barbecue islands with stainless steel fixtures.

Although stainless steel grills will discolor and accumulate grime with regular use, they can keep their original shine with periodic cleaning. We strongly recommend using a surface protectant to prevent smudging and surface rust from accumulating.

The easiest way to clean the grill is immediately after cooking is completed. Doing so will extend the life of your grill, prevent grease fires, and present a pleasant appearance while you grill.

Stainless Steel Care and Cleaning

All exposed stainless steel surfaces require special attention if you want to keep them looking clean and bright. Following these simple instructions will help avoid scratching or damaging the finish and keep your stainless steel attractive.

Cleaning instructions for grill interiors, including racks and burners, are described after this section.

1. Clean

Thoroughly clean stains, food, and grime using a sponge or damp cloth with warm water and a mild dish soap. Use Fantastik or Formula 409 to remove heavier soil.

2. Rinse

Thoroughly rinse all surfaces and dry them completely with a clean towel. Do not allow stainless steel to air dry.

3. Polish

We strongly recommend that you apply a surface protectant to all exposed stainless steel surfaces.

Spray a small amount of WD-40 or Sheila Shine on a piece of paper towel and rub with the grain over the surface of the appliance. Using a clean terry cloth or

CLEANING PRODUCTS AND MATERIALS

 **DO NOT USE** these common cleaning products and materials—they will damage the surface of your stainless steel.

- CLR
- Lime-Away
- Oven cleaner
- Cleansers such as Ajax or Comet
- Ammonia
- Bleach
- Chlorine
- Steel wool pads
- Wire brushes
- Scrapers
- Pumice

 **We recommend this product for stains, rust & discoloration:**

- MHP's SCC Cleaner
(follow directions on bottle)

 **We recommend these products for cleaning your stainless steel:**

- Mild dish detergent such as Dawn
- Formula 409
- Fantastik
- Instant Rust Out (exterior ONLY)
- WD-40 (exterior ONLY)
- Sheila Shine (exterior ONLY)

We have had best success with Instant Rust Out, but WD-40 works very well too. Instant Rust Out is available in some hardware stores. WD-40 is widely available.

Baking soda, lemon oil, olive oil, vinegar, or club soda can also be effective for cleaning light soil on all stainless steel surfaces.

Do not use steel wool or wire brushes to scrub your grill.

For light soil, use a damp sponge or cloth.

For heavier stains, use a Scotch-Brite scrubber or similar product.

paper towel, polish the appliance by rubbing with the grain until excess liquid is removed and the surface shines. It should not be oily to the touch, however some residue is acceptable.

Furniture polish, such as Old English, can be effective for polishing stainless steel and protecting the surface.

⚠ Do not use Instant Rust Out, WD-40, or Sheila Shine near food or on food preparation surfaces as it is a health hazard. This includes the interior of the grill, grill racks, stainless steel sinks, the inside of cabinets, warming drawers, and ovens.

⚠ FIRE HAZARD
NEVER spray WD-40 or Sheila Shine near an open flame! These products are extremely flammable while in their aerosol forms.

Rust Removal

It is a common misconception that stainless steel does not rust. It does not stain, corrode, or rust as easily as ordinary steel (it stains less), but it is not stain-proof. If not properly protected and maintained, it can corrode, pit, and discolor.

⚠ IMPORTANT
Because salt will accelerate rust and corrosion, grill or barbecue island owners who live near the beach need to be diligent in maintaining their stainless steel hardware. You need to clean and polish your stainless steel frequently, apply a protectant, and ensure water does not collect and puddle.

There are two methods of rust removal we recommend:

1. Rust removal with Instant Rust Out:

Spray exterior stainless steel surfaces with Instant Rust Out. Let it stand for about 30 seconds, then wipe with a clean cloth. Apply a second time if necessary.

Instant Rust Out will leave a white residue which can be rinsed off with water. Wipe the grill dry with a clean cloth and apply Sheila Shine or WD-40 as a surface protectant.

2. Rust removal with WD-40 or Sheila Shine:

Spray exterior stainless steel surfaces with WD-40 or Sheila Shine and wipe down with a dry cloth or paper towel until surface is free of rust. If there is significant rust or corrosion, use a Scotch-Brite scrubber.

Both of these products will act as a surface protectant and help resist smudges, stains, and rust.

⚠ CAUTION
Although nitric acid (also called aqua fortis) can be effective for rust removal, it is a highly corrosive chemical. Because of the potential for injury or damage to your stainless steel, we do not recommend using nitric acid.

CLEANING THE INTERIOR OF YOUR GRILL

1. Thoroughly clean stains, food, and grime using a sponge or damp cloth with warm water and a mild dish soap. Use Fantastik or Formula 409 to remove heavier soil.
2. Thoroughly rinse all surfaces and dry them completely with a clean towel. Do not allow water to accumulate and puddle on stainless steel. Water from various sources such as garden hoses contains iron which will give the appearance of rusting on stainless steel. If allowed to stand for long periods of time on stainless steel, it will cause pitting.
3. The racks, flame tamers, and flavor bars can all be removed for cleaning and are dishwasher safe.

Burners

Spiders and small insects occasionally inhabit or make nests in the burner tubes, obstructing the gas flow. Sometimes this results in a type of fire in and around the gas tubes called "flashback". To reduce the risk of flashback, this procedure should be followed at least once a month or when your grill has not been used for an extended period of time.

⚠ IMPORTANT
Prior to starting this procedure, turn OFF all of the gas control knobs, shut off the fuel supply, and disconnect the fuel line.

The burners can be removed by removing the locking pins and lifting them out. The locking pins are located under the grill toward the back. Remove burners from the grill by carefully lifting each burner up and away from the gas valve orifice.

Use a wire brush to clean the outer surface of each burner to remove food residue and dirt. Clean any clogged ports with a stiff wire such as an opened paper clip.

Inspect each burner for damage (cracks and holes). If any damage is found, discontinue grill usage until you replace the burner.

Upon re-installation, inspect the gas valve orifices for cleanliness and condition and the location of the ignitors. When you replace the burners, you do need to replace the locking pins.

Cooking Grates

Use a solution equal parts detergent and hot water just as you would for any cooking equipment. A stiff wire brush or Scotch-Brite pad may also be helpful in removing grime and food deposits.

NOTE

Do not use a wire brush or stainless steel on any other part of your grill or any other stainless steel surface except the cooking grates!

Drip Pans

The full width drip pan will collect grease from the main grill area. The pan should be cleaned after every use to avoid the possibility of a grease fire. Be sure to allow the drip pan to cool prior to cleaning. You may clean the drip pan with a solution of warm soapy water. Make sure to rinse thoroughly to avoid staining, grime and food deposits. Scotch-Brite pads may be used for especially difficult spots. Wipe all areas dry before storing.

SEASONAL CLEANING

If you haven't used your grill in a few months, we recommend that you clean the burners and the interior of your grill. Cleaning the burners periodically will keep them burning evenly and cleanly and help prevent "flashback", a type of fire in and around the gas tubes. This happens when spiders and small insects inhabit or make nests in the burner tubes, obstructing the gas flow.

BEWARE OF SPIDERS

CAUTION: BURNER TUBES MUST BE INSPECTED AND CLEANED BEFORE EACH USE.

Spiders and small insects occasionally spin webs or make nests in the burner tubes. These webs can lead to a gas flow obstruction, which could result in a fire in and around the burner tubes. This type of fire is known as "FLASH-BACK" and can cause serious damage to your appliance and create an unsafe operating condition for the user. Although an obstructed burner tube is not the only cause of "FLASH-BACK" it is the most common cause, and frequent inspection and cleaning of the burner tubes is necessary.

IMPORTANT

Before removing the burners, turn OFF all of the gas control knobs, shut off the fuel supply, and disconnect the fuel line.

1. Remove the components

Remove the racks, the flavor bars, and the flame tamers from the grill and set them aside. They don't need to be in the grill in order to clean them. In fact, all of the items can be cleaned in a dishwasher if you wish.

Leave the drip pan in place for now.

2. Remove the burners

The burners can be removed by taking out the locking pins and carefully lifting them up and away from the valve orifice. The locking pins are located under the grill toward the back. They are used to keep the burners in place and should be reinstalled for safety.

Steam Cleaning Your Grill

Steam cleaning the interior of your grill is very effective and will not void your warranty. Portable hand-held steam cleaners are inexpensive and do not require chemicals. You can steam clean all parts of your Dragon Fire grill, including the burners. When you are finished, make sure you wipe all surfaces down.

If you spray the burners, ignite them and let them burn for about 10 minutes to prevent any water from accumulating inside them.

Covering Your Grill

When not in use and after cooling, cover your grill with our heavy-duty polyester/PVC-lined cover. (See your local Dragon Fire dealer for details.) The cover will help protect your grill from detrimental effects of weather and environmental pollutants. Never put a cover on a hot grill. Allow the grill to cool before covering.

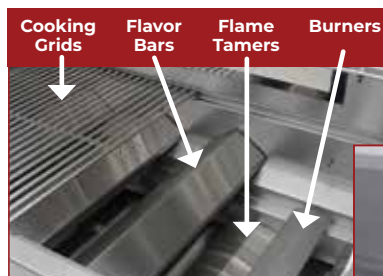

CLEANING AND MAINTENANCE *continued*

3. Clean the burners

Use a wire brush to clean the outer surface of each burner to remove food residue and dirt. Clean any clogged ports with a stiff wire such as an opened paper clip or preferably a drill bit.

Make sure the flow channel is clear. The flow channel is the narrow slot on the bottom of the burner near the anchor post.

Inspect each burner for damage, such as cracks and holes. If any damage is found, don't use the grill until you replace the burner.



4. Clean the grill interior

While the burners are out of the grill, you can use this opportunity to clean the interior of your grill thoroughly. You should still have the drip pan in place to catch water and grime as you clean the grill interior.

When the grill interior is clean, remove the drip pan. Dump out any water and grime residue and spray it off with a garden hose.

Dry both the grill interior and the drip pan thoroughly to prevent water damage.

5. Clean the components

You can clean the racks by first soaking them in warm water and dish detergent and scrubbing them with a wire brush.

Clean the flavor bars and the flame tamers with dish detergent. You can use any kind of scrubber you wish: a non-abrasive pad, Scotch-Brite pad, or a wire brush, depending on your needs.

Dry all of the components thoroughly to prevent water damage.

6. Replace the burners

Before you replace the burners, inspect the gas valve orifices for cleanliness and condition and the location of the ignitors. Set the flame tamers in place before you replace the burners.

Carefully insert the burner into the opening for the valve orifice and gently slide it in. Then set the other end of the burner down so the anchor post rests in the hole.

When you replace the burners, you need to replace the locking pins.



WARNING

For proper operation, burners must be aligned with the valve orifice and seated in the bracket slot. This is accomplished by first placing the burner tube shutter hole securely over the valve orifice and ensuring the male post on the rear of the burner rests in the opening in the grill chassis. Failure to do so could result in a fire and injury.

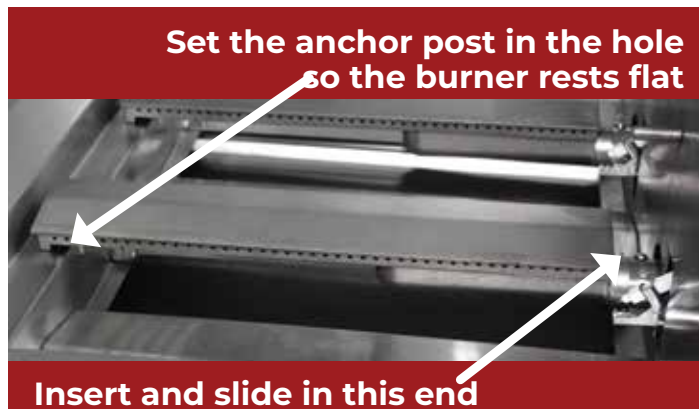

7. Replace the components

Put all of the components back as they were, as shown in step 1.

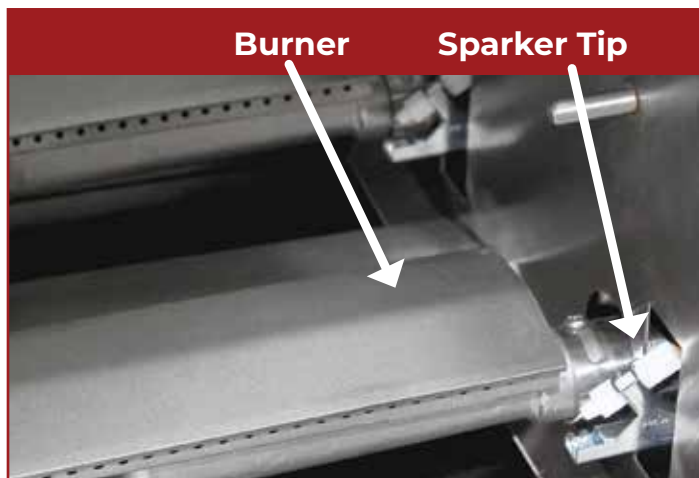

LIGHT BULB REPLACEMENT

- ⚠ WARNING**
Never attempt to replace a light bulb when the grill is in use. Serious burns will result.
- ⚠ WARNING**
Never touch halogen bulbs with your bare fingers. Use a tissue or a small piece of paper to handle bulbs. Oils from your hands will damage halogen bulbs.

Snap-in Light Lens

1. Using a small standard screwdriver, carefully pop out the light lens and set it aside.
2. Using a tissue or small piece of paper, pull the burnt bulb out of the socket.
3. Using a tissue or small piece of paper, carefully push a new bulb into the socket, making sure both wires on the bulb go into the light socket evenly.
4. Replace the light lens by carefully snapping it back in place



TROUBLESHOOTING

▶ Smell of gas is present

Check for loose connections in the gas line. Perform a leak test following the procedure described in this manual (page 14).

▶ Burner does not ignite

Note: Turn off the gas at the source while troubleshooting. Use the following procedure with the figure below.

Check the position of the sparker tip. It should be pointing forward towards the front of the burner.

- Make sure there is a blue spark at the electrode tip to the burner.
- Make sure the igniter wire is connected firmly to the valve ignition device and the electrode.
- Make sure the valve orifice is free of any debris, dust or grease.
- Make sure the valve orifice is aligned inside the front hole of the burner.
- If there is no spark at all, replace the electrode or igniter wire.

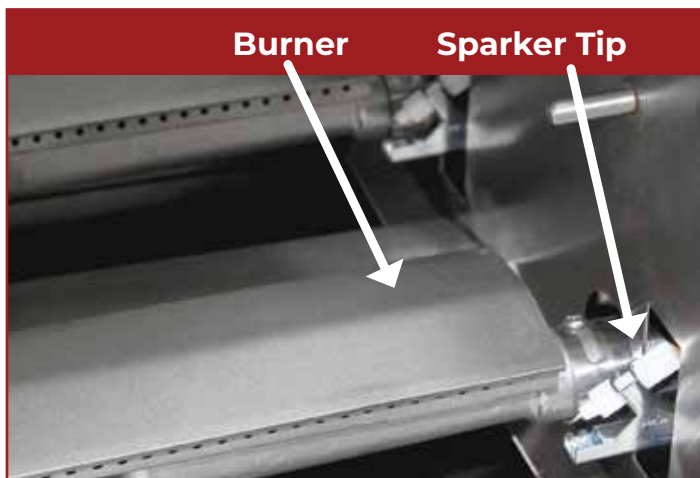

▶ Burner tube is misaligned over the orifice

Reposition the burner tube so that it is properly seated over the orifice.

▶ Obstruction in the gas line

Remove the fuel line from grill. (Do not smoke or perform any maintenance in the vicinity of an open flame.) Open the gas valve for one second to blow out any debris. Close off the gas valve and reconnect the fuel line securely. Let the area ventilate for a few seconds before reconnecting the fuel line.

▶ Yellow Flame

Once the entire burner is operating, check the flame color to be sure that it is mostly blue. Some yellow at the tips may be present due to impurities in the fuel. If the flame is golden or yellow in color, the reason could be seasoning salts, oil film, or other foreign matter on the burner.

▶ Plugged orifice**Unplug the orifice as follows:**

- Remove cooking grills, flame tamer and grease tray.
- Remove burners from the bottom of the firebox by pulling the locking pin from beneath the burner peg using a standard screwdriver or needle nose pliers.
- Carefully lift each burner up and away from the gas orifice.
- Remove the orifice from the control valve.
- Gently clear any obstruction with a fine wire.
- Reinstall the orifice, reinstall the burners over the orifices, and seat each burner peg into position hole at the bottom ledge of the firebox.
- Replace cooking components and grease collectors.

If an obstruction is suspected in the control valve, contact your local Dragon Fire dealer for assistance.

▶ Misalignment of igniter on burner

- Check for proper position of the electrode tip, which should be pointing forward towards the front of the burner and free of grease to allow proper sparking.
- The ignition wire should be connected firmly to the valve ignition device and electrode. Replace the ignition wire if it is frayed or cracked.
- With the gas supply closed and all control knobs set to the off position, check each position igniter individually for the presence of a spark at the electrode. Push each knob in fully and rotate it about 1/4 turn to the left (counter-clockwise) until you hear a loud click. The trigger hitting the strike block should produce a blue spark at the electrode tip. Return control knob to the off position before checking the next igniter.
- While the grill is still hot, wait for a minimum of five minutes before commencing re-ignition. (This allows accumulated gas fumes to clear.) If all checks / corrections have been made and the gas grill still fails to operate properly, contact your local Dragon Fire dealer.

▶ Flashback

When fire occurs in and around the burner tubes, immediately turn off gas at its source and turn the control knobs clockwise to the 'OFF' position. Wait until the grill has cooled off and then clean the burner tubes and burners as described on page of this manual.

CONVERTING FROM LP to NG

WARNING

You must have an authorized service technician perform this procedure . If these instructions are not followed exactly, a fire or explosion may result causing property damage, personal injury or loss of life. ProFire Grills will not be held responsible for an improperly converted gas grill.

All Dragon Fire grills are manufactured as standard liquid propane (LP) grills and can be converted to burn natural gas (NG). However, Dragon Fire DF32 and DF40 grills do not include a conversion kit and it must be ordered separately.

There are three steps required to convert a grill from LP to NG.

You must perform all steps.

Step 1: Switching the regulator behind the grill

Step 2: Changing the burner orifices

Step 3: Adjust low setting

The conversion kit provided with your grill may include **some or all** of the parts shown at right, depending on the size and model of your grill.

The kit contains orifices to convert main burners, rear infrared burners, and the large infrared burner. Your kit will have only the parts you need to convert your grill.

Before you begin, make certain the LP gas source has been disconnected from the grill.

To gain access to the NG regulator, tilt the grill forward.



NG Regulator (one piece)

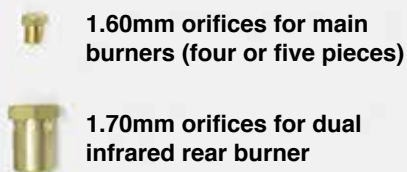

Step 1: Attaching the regulator under the grill

YOU WILL NEED

- **Pipe Wrench**
- **Regulator**
- **Pipe compound suitable for natural gas**

1. Slide grill forward to allow for better access to the manifold connection.
2. Remove the LP gas line and LP gas fitting from end of manifold.
3. Attach NG regulator to end of manifold

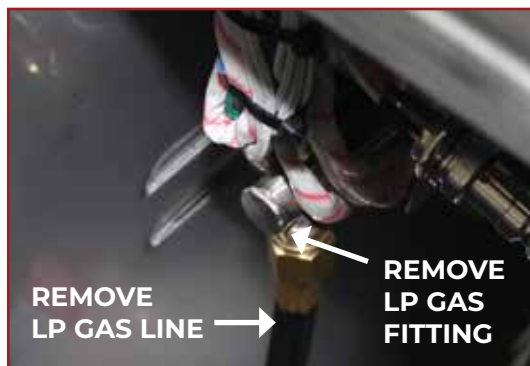

Step 2: Changing the burner orifices

YOU WILL NEED

- 6mm socket or nut driver
- Four or five 1.60mm orifices (*depending on your grill*)
- Pipe compound suitable for natural gas

1. Replace the main burner orifices

- a. Remove the grates, flame tamers, and drip tray from the grill. See figure below.

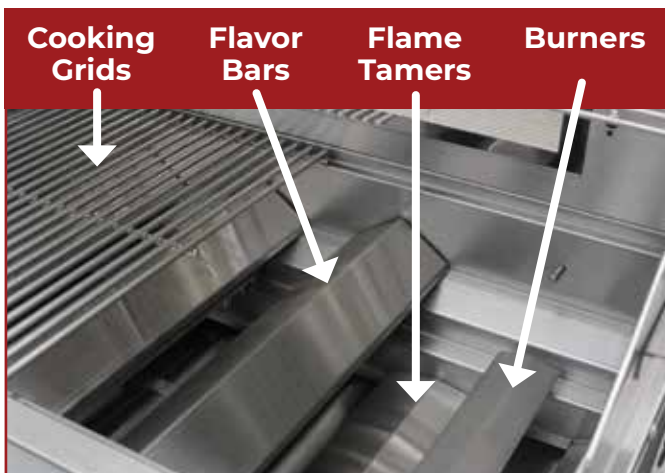

- b. Remove the locking pins from the end of the burners. The locking pins are accessible by removing the drip tray and tilting the grill back. They can be seen underneath the grill in the back. See figures below.
- c. Remove all burners by carefully lifting them up and away from the valve orifice.

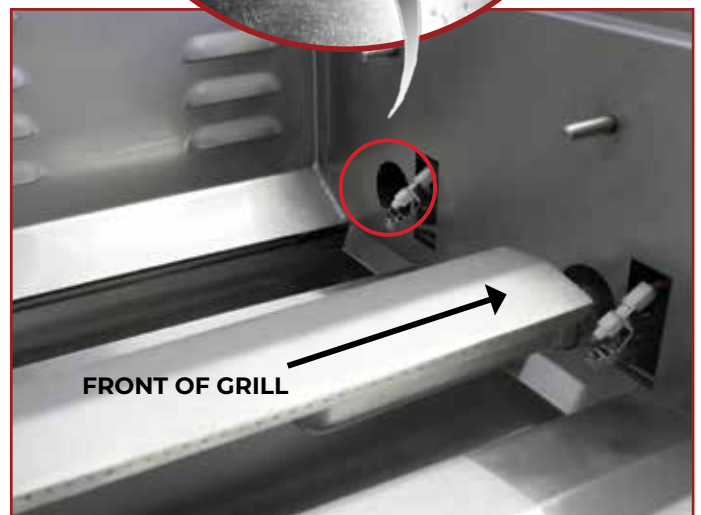
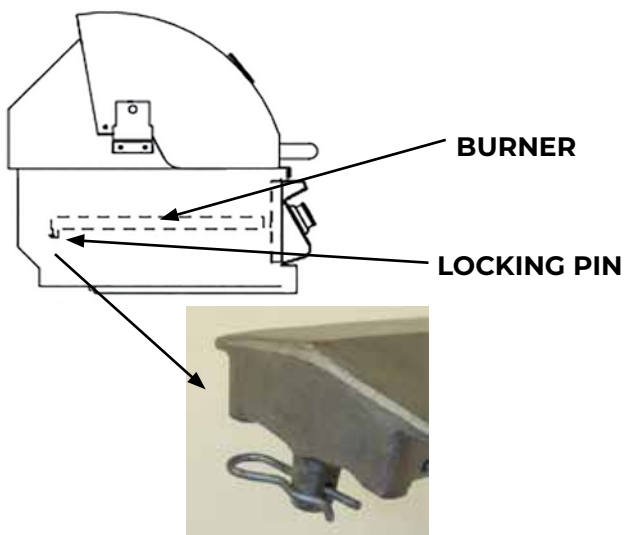

- d. Using a 6mm socket or nut driver, remove the orifice for the burner.
- e. Apply a small amount of pipe compound to the orifice threads.
- f. Screw in the orifice until it is finger tight.
- g. Tighten the orifice with the 6mm wrench.
- h. Repeat the above steps for the remaining burners.
- i. Replace the burners, locking pin, flame tamers, drip tray, and grates.

Step 2: Changing the burner orifices (continued)



YOU WILL NEED

- A 13mm open wrench
- One 1.70mm orifice (for single infrared burner)

2. Replace the rear burner orifices

- Unscrew the back cover from the grill and lift it up and under the grill hood.
- Using a wrench, remove the orifice from the infrared burner.
- Apply pipe compound to the fitting threads where you will place the new orifice.



- Screw on the correct orifice for your grill until it is finger tight.
- Tighten the orifice with the wrench.
- If you have dual infrared burners, repeat the previous steps for the second burner.
- Replace the back cover.

Step 3: Adjust low flame setting

1. Turn burners to low flame setting and test for proper flame height.

Flame should be stable and burning out of each burner port without danger of going out in the lowest setting. (To adjust the LOW flame setting simply light the appliance on the LOW setting and adjust the screw located under the knob on the front of the valve using a flat head screwdriver as seen in the image below.)

2. Remove the knob

To remove the knobs the set screws securing them to the valve stems must be loosened. It will require either a small allen wrench or phillips screw driver depending on the set screw.



3. Remove the Bezel

After removing the knobs the bezel must also be removed to expose the low flame adjustment opening located at approximately 4 o'clock.



Remove the bezel

4. Flame Setting

Insert a small flat blade screw driver and adjust the height of the low flame setting. Flame should be stable and burning out of each port without danger of going out at the lowest setting. Height to be approximately 1/4" above the port.



Low flame adjustment opening

5. Mark the rating plate

After conversion has been completed, mark the rating plate as NG with a permanent marker.

CONVERTING FROM NG to LP**⚠ WARNING**

You must have an authorized service technician perform this procedure. If these instructions are not followed exactly, a fire or explosion may result causing property damage, personal injury or loss of life. ProFire Grills will not be held responsible for an improperly converted gas grill.

There are three steps required to convert a grill from NG to LP.

You must perform all steps.

Step 1: Switching the regulator behind the grill

Step 2: Changing the burner orifices

Step 3: Adjust low setting

The conversion kit provided with your grill may include **some or all** of the parts shown at right, depending on the size and model of your grill.

The kit contains orifices to convert main burners, rear infrared burners, and the large infrared burner. Your kit will have only the parts you need to convert your grill.

Before you begin, make certain the NG gas source has been disconnected from the grill.

To gain access to the LP regulator, tilt the grill forward.

**Step 1: Attaching the regulator under the grill****⚠ YOU WILL NEED**

- Pipe Wrench
- Regulator
- Pipe compound suitable for LP gas

1. Slide grill forward to allow for better access to the manifold connection.
2. Remove the NG gas line and NG gas fitting from end of manifold.
3. Attach LP regulator to end of manifold

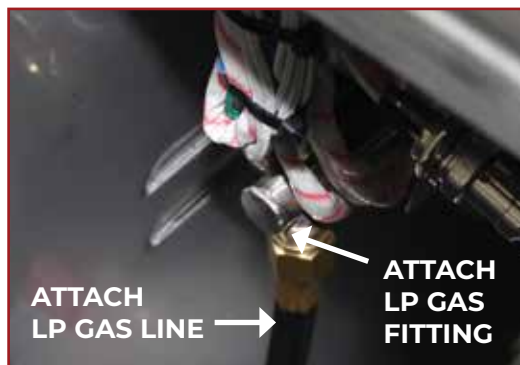

Step 2: Changing the burner orifices

YOU WILL NEED

- 6mm socket or nut driver
- Four or five 1.04mm orifices (*depending on your grill*)
- Pipe compound suitable for LP gas

1. Replace the main burner orifices

- a. Remove the grates, flame tamers, and drip tray from the grill. See figure below.

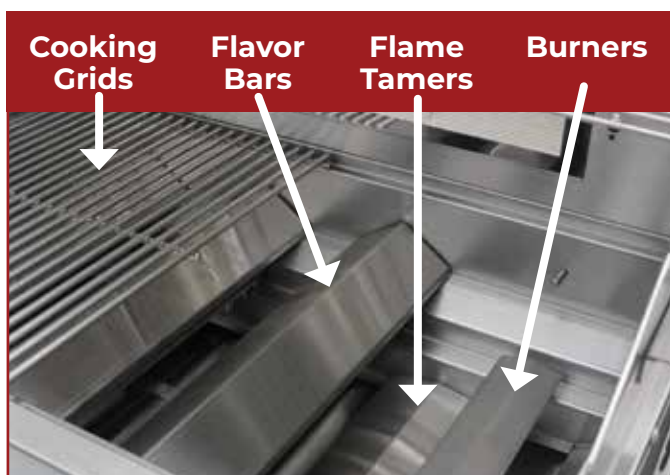

- b. Remove the locking pins from the end of the burners.

The locking pins are accessible by removing the drip tray and tilting the grill back. They can be seen underneath the grill in the back. See figures below.

- c. Remove all burners by carefully lifting them up and away from the valve orifice.

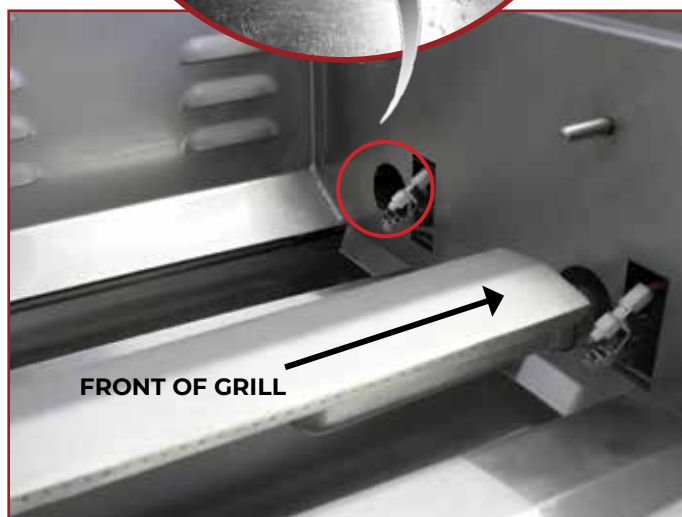
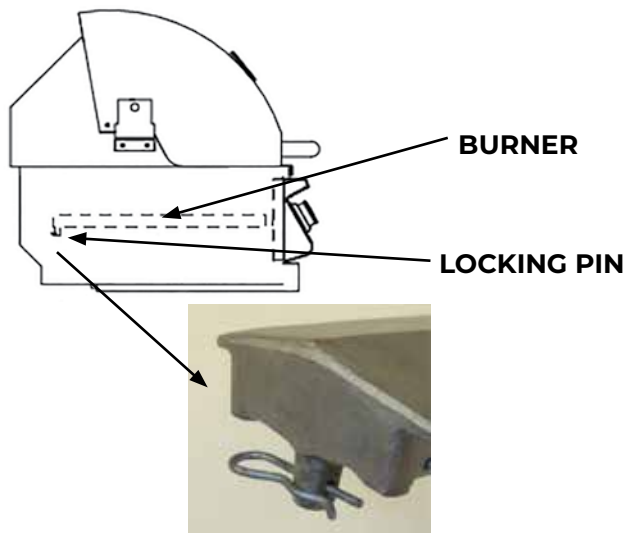

- d. Using a 6mm socket or nut driver, remove the orifice for the burner.
- e. Apply a small amount of pipe compound to the orifice threads.
- f. Screw in the orifice until it is finger tight.
- g. Tighten the orifice with the 6mm wrench.
- h. Repeat the above steps for the remaining burners.
- i. Replace the burners, locking pin, flame tamers, drip tray, and grates.

Step 2: Changing the burner orifices *(continued)***YOU WILL NEED**

- A 13mm open wrench
- One 1.06mm orifice (for single infrared burner)

2. Replace the rear burner orifices

- Unscrew the back cover from the grill and lift it up and under the grill hood.
- Using a wrench, remove the orifice from the infrared burner.
- Apply pipe compound to the fitting threads where you will place the new orifice.

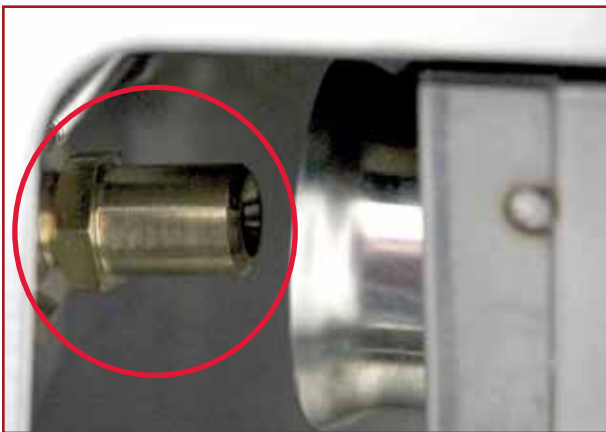

- Screw on the correct orifice for your grill until it is finger tight.
- Tighten the orifice with the wrench.
- If you have dual infrared burners, repeat the previous steps for the second burner.
- Replace the back cover.

Step 3: Adjust low flame setting**1. Turn burners to low flame setting and test for proper flame height.**

Flame should be stable and burning out of each burner port without danger of going out in the lowest setting. (To adjust the LOW flame setting simply light the appliance on the LOW setting and adjust the screw located under the knob on the front of the valve using a flat head screwdriver as seen in the image below.)

2. Remove the knob

To remove the knobs the set screws securing them to the valve stems must be loosened. It will require either a small allen wrench or phillips screw driver depending on the set screw.

**3. Remove the Bezel**

After removing the knobs the bezel must also be removed to expose the low flame adjustment opening located at approximately 4 o'clock.

**Remove the bezel****4. Flame Setting**

Insert a small flat blade screw driver and adjust the height of the low flame setting. Flame should be stable and burning out of each port without danger of going out at the lowest setting. Height to be approximately 1/4" above the port.

**Low flame adjustment opening****5. Mark the rating plate**

After conversion has been completed, mark the rating plate as LG with a permanent marker.

WIRING DIAGRAM

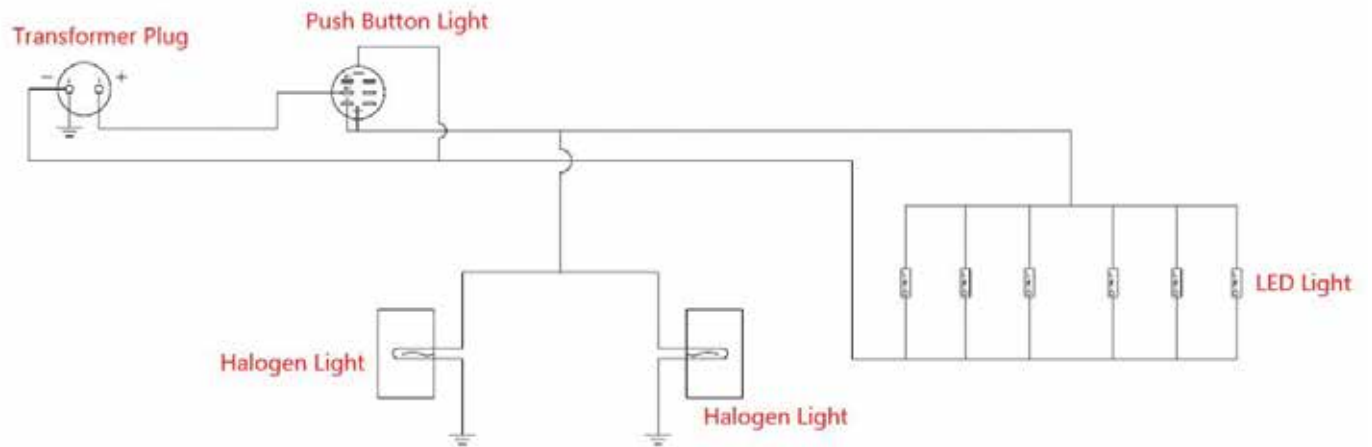

NOTE:
USE TERMINAL CONNECTORS TO ALL WIRE ENDS THAT CONNECT TO ALL ELECTRICAL COMPONENTS. NO SOLDERING.

DF32 DIMENSIONS

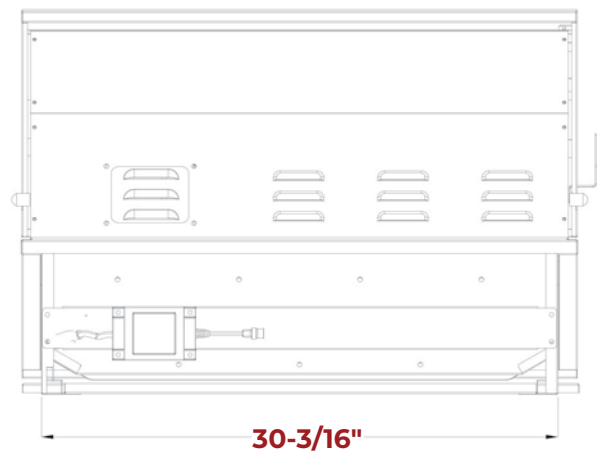
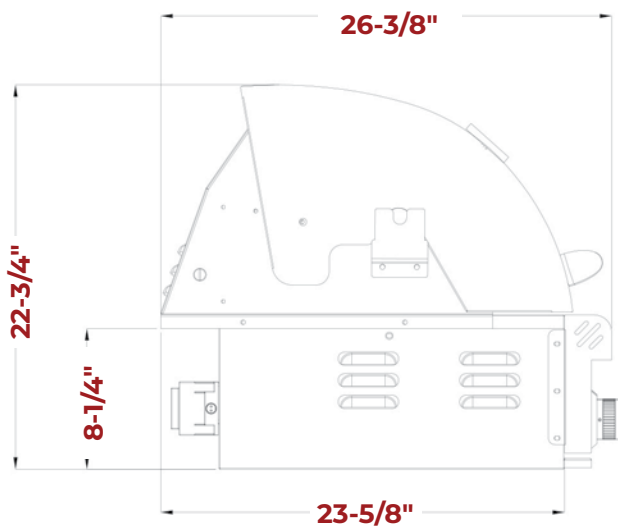
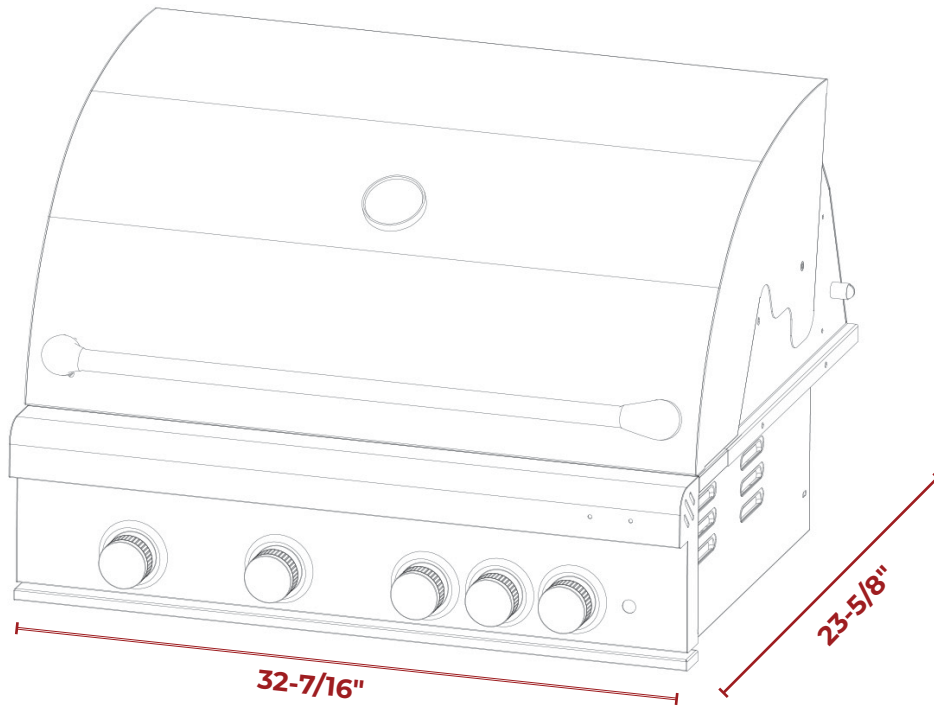

DF40 DIMENSIONS

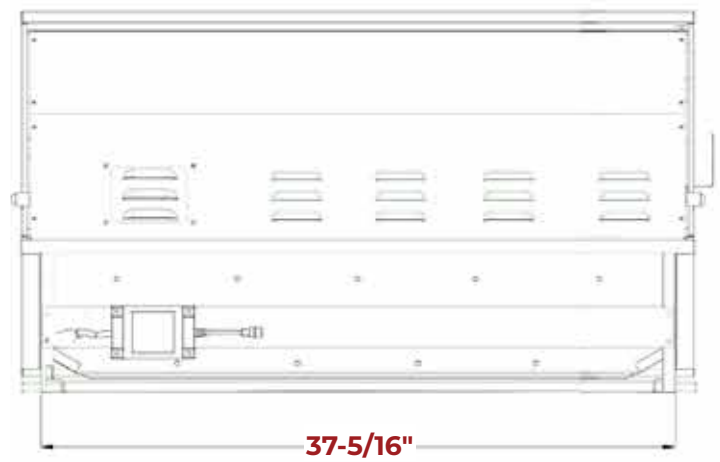
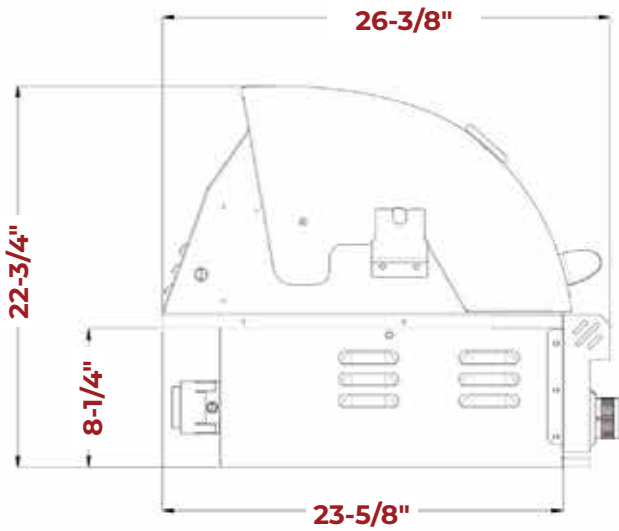
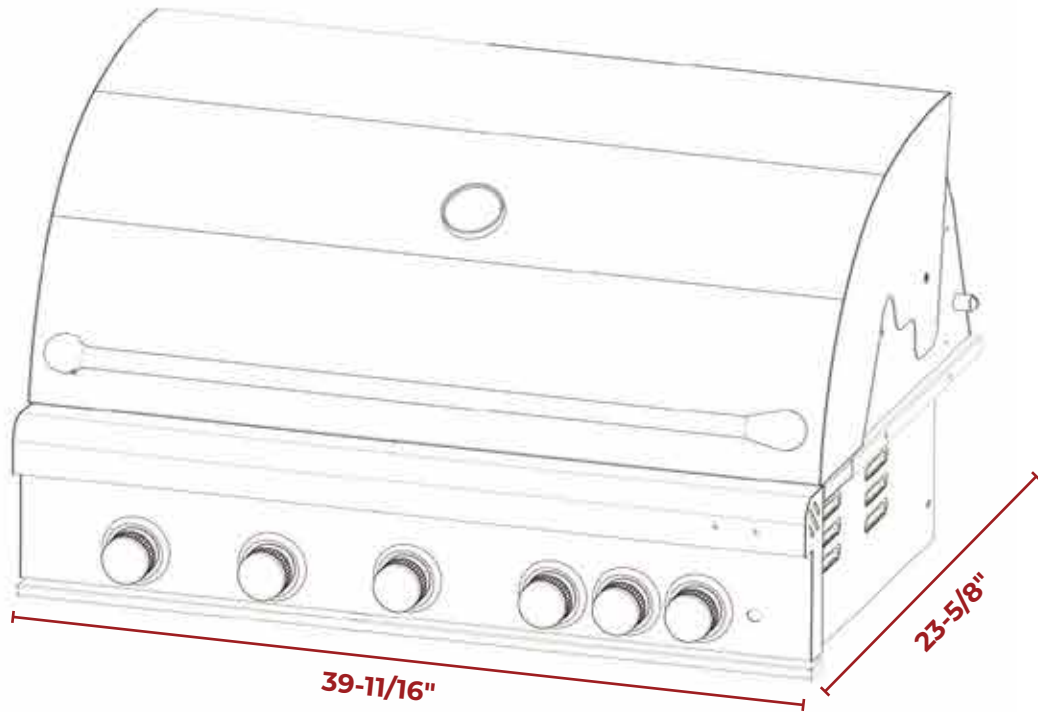

DF32 REPLACEMENT PARTS

See following page for part numbers.

To order replacement parts:

- Contact an authorized selling dealer
- Call ProFire Customer Service at (888) 781-4657
- Visit us at www.DragonFireGrills.com

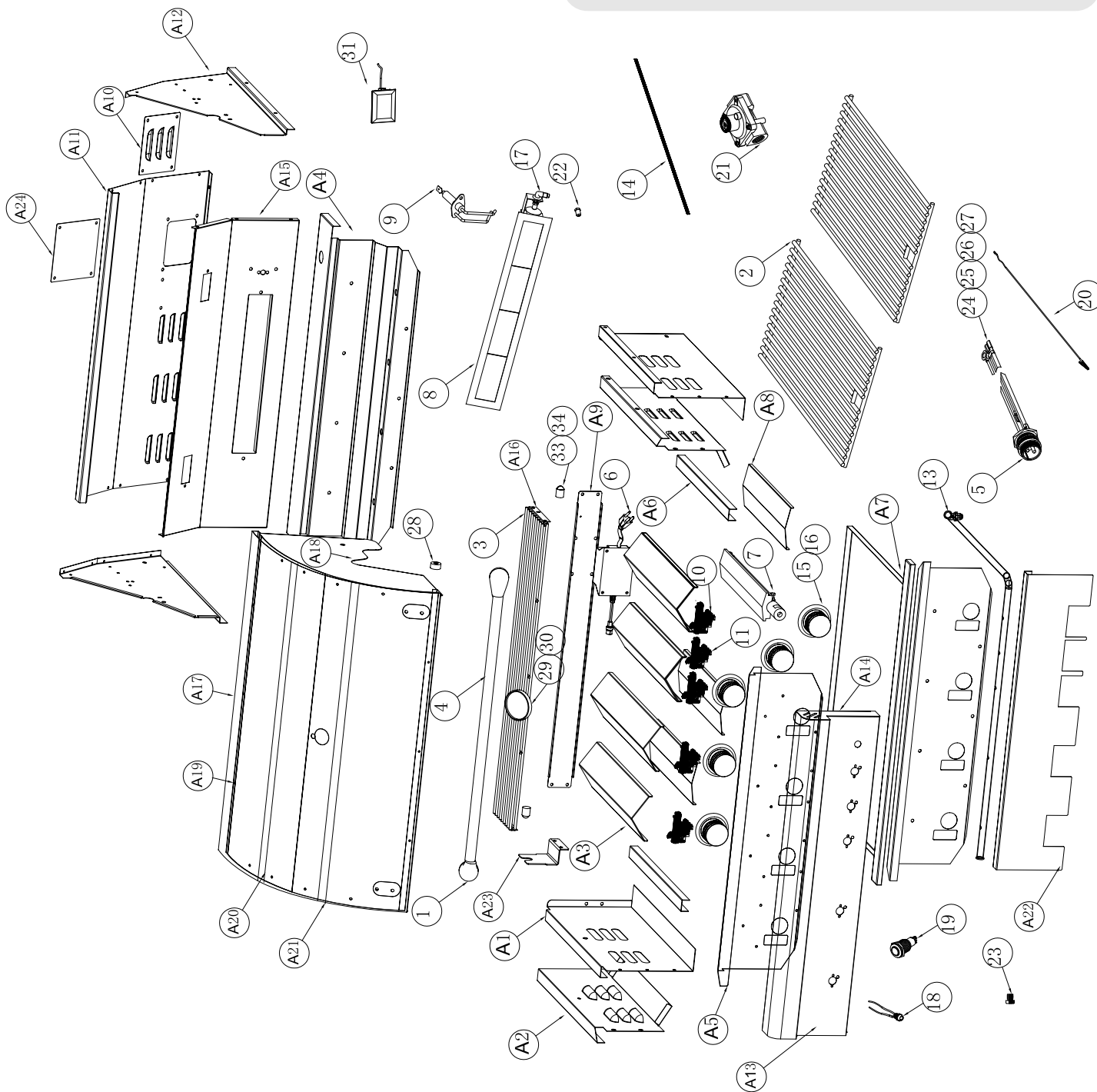

DF32 REPLACEMENT PARTS

Item No.	Part Name	# of Pieces	Part #
A1	Body Side Panel Inner	2	A0A0901-010
A2	Body Side Panel Outer	2	A0A0901-011
A3	Upper Flavor Grids	4	A0A0901-012
A4	Back Body Panel 1	1	A0A0901-013
A5	Body Front Panel	1	A0A0901-014
A6	Manifold Cover	2	A0A0901-015
A7	Drip Tray	1	A0A0901-016
A8	Lower Flavor Grids	3	A0A0901-017
A9	Back Body Panel Cover 1	1	A0A0901-018
A10	Body Back Access Door	1	A0A0901-019
A11	Body Back Panel Cover 2	1	A0A0901-020
A12	Body Side Panel Support	2	A0A0901-021
A13	Control Panel Outer	1	A0A0901-022
A14	Control Side Panel	2	A0A0901-023
A15	Body Back Panel 2	1	A0A0901-024
A16	Warming Rack Bracket	2	A0A0901-025
A17	Head Cover Set 1	1	A0A0901-026
A18	Head Cover Set 2	2	A0A0901-027
A19	Head Cover Set 3	1	A0A0901-029
A20	Head Cover Set 4	1	A0A0901-030
A21	Head Cover Set 5	1	A0A0901-031
A22	Insulation Sheet	1	A0A0901-032
A23	Motor Bracket	2	07874C-029
A24	Nameplate	1	
1	Handle End Cap	2	A0A0901-C33
2	Cooking Grid	2	A0A0901-C03
3	Warm Rack	1	A0A0901-C01
4	Handle	1	A0A0901-C06
5	Electronic Plug	1	A0B0319-C17
6	Transformer	1	A0B0311-C14
7	Main Burner	4	A0B0346-C03
8	Rear Infrared Burner	1	A0B0101-C07
9	Ignitor of E8	1	A0B0319-C11
10	Valve Control	4	A0A0901-C44
11	Rear Infrared Burner Valve	1	A0A0901-C45

DF32 REPLACEMENT PARTS (continued)

Item No.	Part Name	# of Pieces	Part #
12	LPG Regulator	1	A000006-C06
13	Manifold	1	A0A0901-C021
14	Gas Connect Pipe	4	A0B0319-C14
15	Control Knob	5	A0A0901-C46
16	Control Knob Bezel	5	A0A0901-C47
17	Elbow of Infrared Burner	1	A0B0102-C13
18	LED Light	5	A0A0901-C07
19	Light Switch	1	A0A0189-999
20	Ignitor Clip	1	A0B0101-C09
21	NG Regulator	1	A0B0322-C11
22n	NG Orifice/Back	1	A0B0371-C05
22p	LPG Orifice/Back	1	A0B0371-C05
23n	NG Orifice/main	4	A0B0371-C33
23p	LPG Orifice/main	4	A0B0371-C33
24	Cable Wire	1	A0B0311-C02
25	Cable Wire	1	A0B0311-C03
26	Cable Wire	1	A0B0311-C04
27	Cable Wire	1	A0B0311-C05
28	Hood Shaft	2	A0A0901-C04
29	Thermometer	1	A0A0901-C08
30	Thermometer Bezel	1	A0A0901-C09
31	Halogen Light	2	A0B0319-C21
32	Small Box	1	A0B0371-B03
33	Hood Support	2	A0C0101-C01
34	Hood Support Bolt	2	A0C0101-C05

DF40 REPLACEMENT PARTS

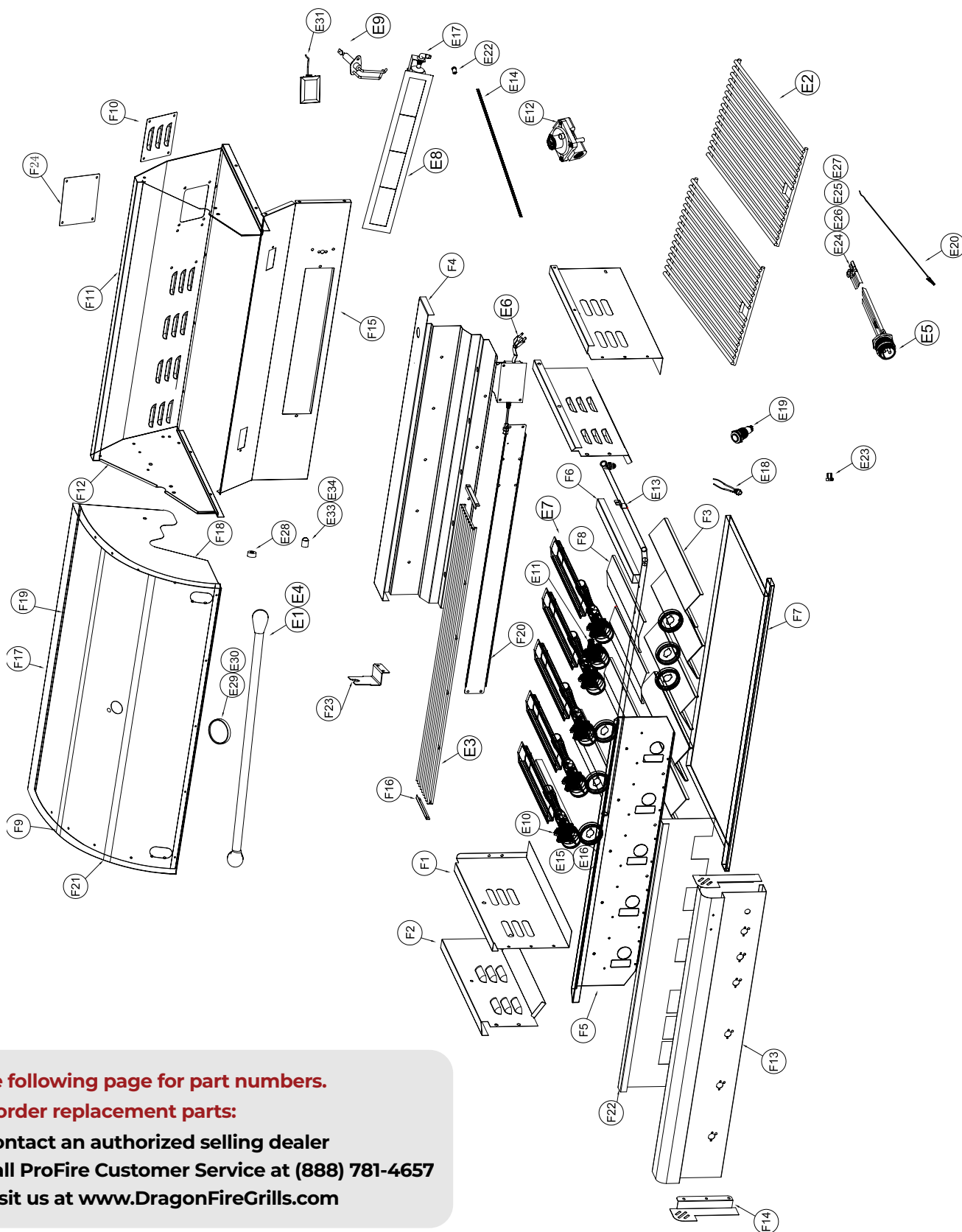

See following page for part numbers.
To order replacement parts:

- Contact an authorized selling dealer
- Call ProFire Customer Service at (888) 781-4657
- Visit us at www.DragonFireGrills.com

DF40 REPLACEMENT PARTS

Item No.	Part Name	# of Pieces	Part #
F1	Body Side Panel Inner	2	A0A0901-010
F2	Body Side Panel Outer	2	A0A0901-011
F3	Upper Flavor Grids	5	A0A0901-012
F4	Back Body Panel 1	1	A0A0902-013
F5	Body Front Panel	1	A0A0902-014
F6	Manifold Cover	2	A0A0901-015
F7	Drip Tray	1	A0A0902-006
F8	Lower Flavor Grids	4	A0A0901-017
F9	Head Cover Set 1	1	A0A0902-016
F10	Body Back Access Door	1	A0A0901-019
F11	Body Back Panel Cover 1	1	A0A0902-007
F12	Body Side Panel Support	2	A0A0901-021
F13	Control Panel Outer	1	A0A0902-008
F14	Control Side Panel	2	A0A0901-023
F15	Body Back Panel 2	1	A0A0902-011
F16	Warming Rack Bracket	2	A0A0901-025
F17	Head Cover Set 2	1	A0A0902-014
F18	Head Cover Set 3	2	A0A0901-027
F19	Head Cover Set 4	1	A0A0902-015
F20	Body Back Panel Cover 2	1	A0A0902-013
F21	Head Cover Set 5	1	A0A0902-017
F22	Insulation Sheet	1	A0A0902-021
F23	Motor Bracket	2	07874C-029
F24	Nameplate	1	
E1	Handle End Cap	2	A0A0901-C33
E2	Cooking Grid	3	A0A0902-C23
E3	Warm Rack	1	A0A0902-C01
E4	Handle	1	A0A0902-C04
E5	Electronic Plug	1	A0B0319-C17
E6	Transformer	1	A0B0311-C14
E7	Main Burner	5	A0B0346-C03
E8	Rear Infrared Burner	1	A0B0101-C07
E9	Ignitor of E8	1	A0B0319-C11
E10	Valve Control	5	A0A0901-C44
E11	Rear Infrared Burner Valve	1	A0A0901-C45

DF40 REPLACEMENT PARTS (continued)

Item No.	Part Name	# of Pieces	Part #
E12	LPG Regulator	1	A000006-C06
E13	Manifold	1	A0A0902-C03
E14	Gas Connect Pipe	1	A0B0102-C01
E15	Control Knob	6	A0A0901-C46
E16	Control Knob Bezel	6	A0A0901-C47
E17	Elbow of Infrared Burner	1	A0B0102-C13
E18	LED Light	6	A0A0901-C07
E19	Light Switch	1	A0A0189-999
E20	Ignitor Clip	1	A0B0101-C09
E21	NG Regulator	1	A0B0322-C11
E22n	NG Orifice/Back	1	A0B0371-C05
E22p	LPG Orifice/Back	1	A0B0371-C05
E23n	NG Orifice/main	5	A0B0371-C33
E23p	LPG Orifice/main	5	A0B0371-C33
E24	Cable Wire	1	A0B0311-C02
E25	Cable Wire	1	A0B0311-C03
E26	Cable Wire	1	A0B0311-C04
E27	Cable Wire	1	A0B0311-C05
E28	Hood Shaft	2	A0A0901-C04
E29	Thermometer	1	A0A0901-C08
E30	Thermometer Bezel	1	A0A0901-C09
E31	Halogen Light	2	A0B0319-C21
E32	Small Box	1	A0B0371-B03
E33	Hood Support	2	A0C0101-C01
E34	Hood Support Bolt	2	A0C0101-C05

LIMITED WARRANTY

This Limited Warranty is extended to the original purchaser of a Dragon Fire DF32 or DF40 grill manufactured after January 1, 2019 and installed for residential use in the United States.



Limited Lifetime Warranty (Against Rust-Through)

- Stainless Steel Body
- Stainless Steel Hoods & Liners
- Cast Stainless Steel Burners
- Stainless Steel Heat Plates & Drip Pan
- Stainless Steel Cart & Shelves
- Gas Valves



5-Year Warranty

- Infrared Burners



1-Year Warranty

All other components including:

- Ignition System
- Lights
- Knobs
- Gas Manifold
- Handle
- Thermometer
- Casters

This Limited Warranty is void if ProFire (the “Manufacturer”) or its designated representative determines that the grill has been subjected to damage or failure due to installation of aftermarket parts that are not genuine ProFire branded parts and accessories. This disclaimer includes, but is not limited to gas valves, gas nozzles, infrared burners, lights and transformers. Genuine ProFire brand parts and accessories are built to our highest standards of quality, durability and performance, and they are designed to work with your grill to ensure optimal performance and function.

Performance

In the event of a defect covered by this Limited Warranty, notify your Dragon Fire dealer or ProFire as soon as possible and use all reasonable means to protect the grill from further damage. Upon receipt of a valid form of proof of purchase, a designated service representative will correct the defect, subject to the terms and conditions contained in this Lim-

ited Warranty. There will be no charge or parts, although providing access to affect the repair is your responsibility as the grill owner. Freight charges for replacement parts, labor and labor related trip charges necessary to repair the grill are also the responsibility of the grill owner. If the Manufacturer determines that repair of the covered defect is not feasible, it reserves the right to provide replacement grill instead. In such an event, reasonable costs for removal of the original grill, shipping costs from the factory for the replacement grill and delivery and installation of the replacement will be your responsibility as the grill owner. Any replacement parts and or grill will carry the balance of the original grill warranty. Grill covers are not included. This warranty ends either by specified time frame listed above, owner-transfer, relocation, commercial installation or installation of any component other than by manufacturer.

LIMITED WARRANTY *continued*

Warranty Limitations

This Limited Warranty is void if ProFire or its designated representative determines that the grill has been subjected to alteration, neglect, misuse or abuse, or freight damage caused by the common carrier; any repairs or fuel conversion have been attempted by anyone other than a designated representative; or if the failure is caused by accident, acts of God or other causes beyond the control of the Manufacturer. Neglect, misuse and abuse include any installation, operation or maintenance of the grill other than in accordance with the instructions contained in the owner's manual provided with the grill. Corrosion, scratching and discoloration due to improper use and care of this outdoor product, is excluded from this warranty.

Limitations

The Manufacturer disclaims all warranties, expressed or implied, in fact or in law, to the extent allowed by your State's Law, including the warranty of merchantability and fitness for use, except as stated specifically herein. All warranty service must be performed by the Manufacturer or its designated representative using authorized Dragon Fire parts. No agent, dealer, distributor, Service Company or other party is authorized to change, modify or extend the terms of this limited warranty in any manner whatsoever. The Manufacturer will not be responsible for any statements or representations made in any form that go beyond, are broader than, or are inconsistent with any authorized literature or specifications furnished by ProFire.

Disclaimers

The Manufacturer and its representatives shall not be liable for any injury, loss, cost or other damage, whether incidental or consequential, arising out of any defect covered by this limited warranty, including without limitation, loss of use of the grill and cost for removal of defective product even if the Manufacturer was advised of the possibility of damage. The liability of the Manufacturer under this limited warranty, if any, shall not exceed the original amount paid for the defective product. Coverage under this limited warranty shall commence as of the original date of purchase and the duration of such coverage shall not extend for any reason whatsoever beyond the stated time periods. These disclaimers shall be equally applicable to any service provided by the Manufacturer and its designated representatives.

Legal Rights

This Limited Warranty gives you specific legal rights. You may also have other rights that vary from state to state. Some states do not allow limitations on how long an implied warranty lasts, so this limitation may not apply to you.

DON'T FORGET TO REGISTER YOUR NEW PRODUCT

Visit www.DragonFireGrills.com to complete our online registration form

Locating the product serial number

The serial number of your Dragon Fire grill is located on the back and is visible when the hood is down. You will need this number to properly register your grill and activate coverage. Write this information in the space provided below.



Grill Model: _____

Grill Serial Number: _____

Type of Fuel (check one): Liquid Propane (LP) Natural Gas (NG) _____

Date Purchased: _____

Date Installed: _____

Dragon Fire Dealer's Phone Number: _____

Dragon Fire Dealer's Address: _____

**For customer service please contact your authorized dealer immediately.
If you need additional information and/or assistance, please contact:**



ProFire Grills
5565 North 124th Street • Butler, WI 53007
Toll Free: 1-888-781-4657 • Fax: 1-888-781-3965

California Proposition 65 Warning: Chemicals known to the State of California to cause cancer, birth defects or other reproductive harm are found in and/or created by the combustion of natural gas, propane, butane and other fuels. Always operate this unit as described in the owner's manual and in well ventilated areas.