

ProFire



***Professional Quality Grills
For Your Backyard***

www.mhpgrills.com

 **Made in America**

ProFire Grills | 5565 North 124th Street, Butler, WI 53007 | 262.781.4657 • 888.781.4657 | www.mhpgrills.com



Why ProFire Grills? In a word...**Craftsmanship**

DESIGN & CONSTRUCTION

- Proudly made in the USA
- Complete commercial grade stainless steel grill line available with a wide variety of price points and built to fit many common built-in openings
- Designed and built to withstand the harshest of coastal conditions
- First in the industry to use all stainless steel components throughout the entire grill
- One of the heaviest gauge heat plates in the industry

EASE-OF-USE

- Grills require almost no assembly
- ProFire's roll top lid design is well balanced and opens effortlessly
- Easily customize grills for specific needs and location by choosing from a variety of features and adding optional upgrades

WORRY-FREE PERFORMANCE

- **Backed by the most comprehensive lifetime warranty in the industry**
- Friendly and knowledgeable customer service specialists readily available for the lifetime of the grill

Burner Systems

Our burner systems are available on all ProFire Grill Models

Standard "Traditional" Burner System

Quality commercial grade 16-gauge stainless steel tube burners are paired with our 14-gauge stainless steel flavor plates, to distribute heat evenly over the entire grilling surface.

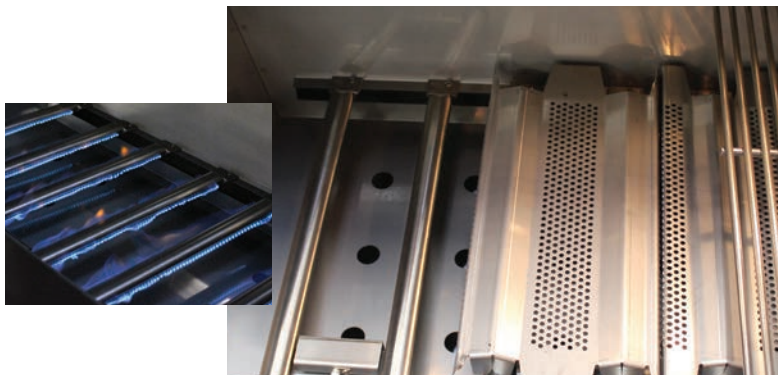

ProFire Briquette System

This works with our traditional burners to turn your grill into a true all briquette system. The briquettes, which cover the whole bottom of the grill, are placed at a greater distance from the cooking grate, translating into less flare-ups and a more even heat pattern. Since porcelain is a better conductor of heat this also means that our system will cook more reliably and produce better results.



« BRIQUETTE SYSTEM WITH HYBRID BURNERS



BRIQUETTE » SYSTEM WITH TRADITIONAL BURNERS

Hybrid Burner System

Offers the best of both worlds. Spacious 9"x14-3/4" Infrared burner paired with our traditional stainless steel burners. Infrared burners provide an intense heat that seals in meat juices and reduces flare-ups.

Advantages of Infrared

- Fast...heats up in approximately 3 minutes
- Intense heat—seals in meat juices for better flavor
- Time saver...heats up faster with shorter grilling time
- High intense heat reduces flare-ups by vaporizing juices instantly
- Spacious 9" x 14-3/4" Infrared Burner
- 32,000 BTU Output

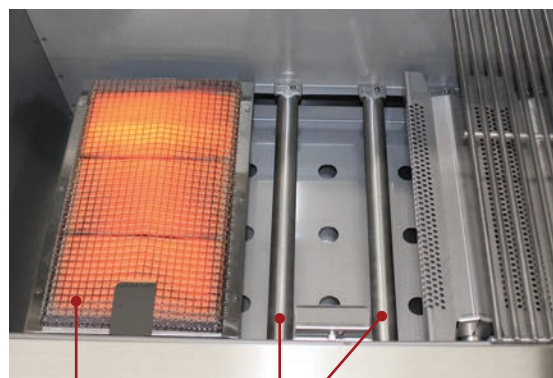

INFRARED BURNER

STANDARD BURNERS

PROFIRE DLX SERIES GRILL HEADS

The **ProFire DLX Series**, complete with a sleek radius hood, interior halogen lights and a secondary cooking surface, these new American-made stainless steel models are packed with features, style and quality construction. Available in three sizes – 27", 36" and 48" – with overall cooking areas ranging from 675 sq. inches up to 1,357 sq. inches and BTUs ranging from 44,000 to 98,000.



- 1 LED CONTROL KNOB BEZELS**
The blue lights provide for added convenience and style while grilling.
- 2 WARMING RACK**
Stainless Steel warming rack provides a secondary cooking area.
- 3 INTEGRATED LIGHTS**
Integrated double halogen interior lights provide ample lighting to make grilling at night a breeze.
- 4 STAINLESS STEEL COOKING GRIDS**
Commercial Grade Stainless Steel Cooking grids have 5/16" thick rods to accommodate small items.
- 5 FLAVOR PLATES**
These 14-gauge stainless steel, self-cleaning plates distribute heat evenly over the entire grilling surface and produce barbecue flavor while reducing flare-ups.
- 6 TRADITIONAL BURNERS**
Quality commercial grade 16-gauge stainless steel burners.



Hybrid Burners



Briquette Burner System

SEARMAGIC COOKING GRIDS

These high-performance, reversible, rust-free, hard-coat anodized aluminum cooking grids heat up faster and cook foods at a uniform temperature. The ribbed side is perfect for steaks and burgers while the smooth side is ideal for delicate items such as fish or vegetables.

All grill models are available with or without this feature.



Ribbed Side



Smooth Side

PROFIRE GRILL LIDS

Two layers of heavy-duty stainless steel to prevent heat loss and keep the outer lid cooler. Seamless lids are accented with a polished mirror finish.



REAR INFRARED BURNER

Heats up fast to quickly put a seal around meats for juicier and more moist results. Comes with a heavy-duty rotisserie.

All grill models are available with or without this feature.



ELECTRONIC MULTIPLE SPARK IGNITION

Allows for quick, easy and reliable starts.

**Traditional Burners
PROFIRE
DELUXE SERIES
Grill Heads**



**CUT-OUT
DIMENSIONS**
48-1/4" W
10" H
24-1/2" D



**CUT-OUT
DIMENSIONS**
48-1/4" W
10" H
24-1/2" D

	PFDLX48R	PFDLX48G	PFDLX48RS	PFDLX48S
Total Grilling Area	1,242 Sq. In.	1,357 Sq. In.	918 Sq. In.	1,003 Sq. In.
Primary Grilling Area	966 Sq. In.	966 Sq. In.	714 Sq. In.	714 Sq. In.
Warming Rack	276 Sq. In.	391 Sq. In.	204 Sq. In.	289 Sq. In.
BTU's	88,000	88,000	66,000	66,000
# of 11,000 BTU Burners (Traditional)	8	8	6	6
# of Controlled Cooking Zones	4	4	3	3
Infrared Rear Burner BTU's	13,500	—	11,500	—
Heavy-Duty Rotisserie	✓	—	✓	—
Integrated Side Burner	—	—	Double	Double
Integrated Side Burner BTU's	—	—	30,000	30,000
Stainless Steel Cooking Grids	Standard	Standard	Standard	Standard
SearMagic Cooking Grids	PFDLXSM48R	PFDLXSM48G	PFDLXSM48RS	PFDLXSM48RS
Integrated Halogen Lights	✓	✓	✓	✓
LED Control Knob Bezels	✓	✓	✓	✓

**Traditional Burners
PROFIRE
DELUXE SERIES
Grill Heads**



**CUT-OUT
DIMENSIONS**
36-1/4" W
10" H
24-1/2" D



**CUT-OUT
DIMENSIONS**
27-1/4" W
10" H
24-1/2" D

	PFDLX36R	PFDLX36G	PFDLX27R	PFDLX27G
Total Grilling Area	918 Sq. In.	1,003 Sq. In.	675 Sq. In.	737 Sq. In.
Primary Grilling Area	714 Sq. In.	714 Sq. In.	525 Sq. In.	525 Sq. In.
Warming Rack	204 Sq. In.	289 Sq. In.	150 Sq. In.	212 Sq. In.
BTU's	66,000	66,000	44,000	44,000
# of 11,000 BTU Burners (Traditional)	6	6	4	4
# of Controlled Cooking Zones	3	3	2	2
Infrared Rear Burner BTU's	11,500	11,500	11,500	—
Heavy-Duty Rotisserie	✓	—	✓	—
Stainless Steel Cooking Grids	Standard	Standard	Standard	Standard
SearMagic Cooking Grids	PFDLXSM36R	PFDLXSM36G	PFDLXSM27R	PFDLXSM27G
Integrated Halogen Lights	✓	✓	✓	✓
LED Control Knob Bezels	✓	✓	✓	✓

Briquette System PROFIRE DELUXE SERIES Grill Heads



**CUT-OUT
DIMENSIONS**
48-1/4" W
10" H
24-1/2" D



**CUT-OUT
DIMENSIONS**
48-1/4" W
10" H
24-1/2" D

	BQDLX48R	BQDLX48RIH	BQDLX48G	BQDLX48GIH	BQDLX48RS	BQDLX48RSIH	BQDLX48S	BQ48DLXSIH
Total Grilling Area	1,236 Sq. In.	1,236 Sq. In.	1,357 Sq. In.	1,357 Sq. In.	914 Sq. In.	914 Sq. In.	1,003 Sq. In.	1,003 Sq. In.
Primary Grilling Area	966 Sq. In.	966 Sq. In.	966 Sq. In.	966 Sq. In.	714 Sq. In.	714 Sq. In.	714 Sq. In.	714 Sq. In.
Warming Rack	270 Sq. In.	270 Sq. In.	391 Sq. In.	391 Sq. In.	200 Sq. In.	200 Sq. In.	289 Sq. In.	289 Sq. In.
BTU's	88,000	98,000	88,000	98,000	66,000	76,000	66,000	76,000
# of 11,000 BTU Burners (Traditional)	8	6	8	6	6	4	6	4
# of 32,000 BTU Burners (Infrared)	—	1	—	1	—	1	—	1
# of Controlled Cooking Zones	4	4	4	4	3	3	3	3
Infrared Rear Burner BTU's	13,500	13,500	—	—	11,500	11,500	—	—
Heavy-Duty Rotisserie	✓	✓	—	—	✓	✓	—	—
Integrated Side Burner	—	—	—	—	Double	Double	Double	Double
Integrated Side Burner BTU's	—	—	—	—	30,000	30,000	30,000	30,000
Stainless Steel Cooking Grids	Standard	Standard	Standard	Standard	Standard	Standard	Standard	Standard
SearMagic Cooking Grids	PFDLXSM48R	—	PFDLXSM48G	—	PFDLXSM48RS	—	PFDLXSM48S	—
Integrated Halogen Lights	✓	✓	✓	✓	✓	✓	✓	✓
LED Control Knob Bezels	✓	✓	✓	✓	✓	✓	✓	✓

Briquette System PROFIRE DELUXE SERIES Grill Heads



**CUT-OUT
DIMENSIONS**
36-1/4" W
10" H
24-1/2" D



**CUT-OUT
DIMENSIONS**
27-1/4" W
10" H
24-1/2" D

	BQDLX36R	BQDLX36RIH	BQDLX36G	BQDLX36GIH	BQDLX27R	BQDLX27RIH	BQDLX27G	BQDLX27GIH
Total Grilling Area	914 Sq. In.	914 Sq. In.	1,003 Sq. In.	1,003 Sq. In.	665 Sq. In.	665 Sq. In.	737 Sq. In.	737 Sq. In.
Primary Grilling Area	714 Sq. In.	714 Sq. In.	714 Sq. In.	714 Sq. In.	525 Sq. In.	525 Sq. In.	525 Sq. In.	525 Sq. In.
Warming Rack	200 Sq. In.	200 Sq. In.	289 Sq. In.	289 Sq. In.	140 Sq. In.	140 Sq. In.	212 Sq. In.	212 Sq. In.
BTU's	66,000	76,000	66,000	76,000	44,000	54,000	44,000	54,000
# of 11,000 BTU Burners (Traditional)	6	4	6	4	4	2	4	2
# of 32,000 BTU Burners (Infrared)	—	1	—	1	—	1	—	1
# of Controlled Cooking Zones	3	3	3	3	2	2	2	2
Infrared Rear Burner BTU's	11,500	11,500	—	—	11,500	11,500	—	—
Heavy-Duty Rotisserie	✓	✓	—	—	✓	✓	—	—
Stainless Steel Cooking Grids	Standard	Standard	Standard	Standard	Standard	Standard	Standard	Standard
SearMagic Cooking Grids	PFDLXSM36R	—	PFDLXSM36G	—	PFDLXSM27R	—	PFDLXSM27G	—
Integrated Halogen Lights	✓	✓	✓	✓	✓	✓	✓	✓
LED Control Knob Bezels	✓	✓	✓	✓	✓	✓	✓	✓

6 MOUNTING & DESIGN OPTIONS—We have a variety of options to create your ideal outdoor entertainment area.

**Hybrid Burners
PROFIRE
DELUXE SERIES
Grill Heads**



**CUT-OUT
DIMENSIONS**
48-1/4" W
10" H
24-1/2" D



**CUT-OUT
DIMENSIONS**
48-1/4" W
10" H
24-1/2" D

	PFDLX48RIH	PFDLX48GIH	PFDLX48RSIH	PFDLX48SIH
Total Grilling Area	1,242 Sq. In.	1,357 Sq. In.	918 Sq. In.	1,003 Sq. In.
Primary Grilling Area	966 Sq. In.	966 Sq. In.	714 Sq. In.	714 Sq. In.
Warming Rack	276 Sq. In.	391 Sq. In.	204 Sq. In.	289 Sq. In.
BTU's	98,000	98,000	76,000	76,000
# of 11,000 BTU Burners (Traditional)	6	6	4	4
# of 32,000 BTU Burners (Infrared)	1	1	1	1
# of Controlled Cooking Zones	4	4	3	3
Infrared Rear Burner BTU's	13,500	—	11,500	—
Heavy-Duty Rotisserie	✓	—	✓	—
Integrated Side Burner	—	—	Double	Double
Integrated Side Burner BTU's	—	—	30,000	30,000
Stainless Steel Cooking Grids	Standard	Standard	Standard	Standard
Integrated Halogen Lights	✓	✓	✓	✓
LED Control Knob Bezels	✓	✓	✓	✓

**Hybrid Burners
PROFIRE
DELUXE SERIES
Grill Heads**



**CUT-OUT
DIMENSIONS**
36-1/4" W
10" H
24-1/2" D



**CUT-OUT
DIMENSIONS**
27-1/4" W
10" H
24-1/2" D

	PFDLX36RIH	PFDLX36GIH	PFDLX27RIH	PFDLX27GIH
Total Grilling Area	918 Sq. In.	1,003 Sq. In.	675 Sq. In.	737 Sq. In.
Primary Grilling Area	714 Sq. In.	714 Sq. In.	525 Sq. In.	525 Sq. In.
Warming Rack	204 Sq. In.	289 Sq. In.	150 Sq. In.	212 Sq. In.
BTU's	76,000	66,000	54,000	54,000
# of 11,000 BTU Burners (Traditional)	4	4	2	2
# of 32,000 BTU Burners (Infrared)	1	1	1	1
# of Controlled Cooking Zones	3	3	2	2
Infrared Rear Burner BTU's	11,500	—	11,500	—
Heavy-Duty Rotisserie	✓	—	✓	—
Stainless Steel Cooking Grids	Standard	Standard	Standard	Standard
Integrated Halogen Lights	✓	✓	✓	✓
LED Control Knob Bezels	✓	✓	✓	✓

PROFIRE PF SERIES GRILL HEADS

Our **Professional PF Series** grill heads incorporate a contemporary, linear design with a multitude of features, style and quality construction. Made in America of durable stainless steel and available in three sizes. We also offer a variety of popular options—including our hybrid burner for greater cooking versatility and your choice of quality Stainless Steel cooking grids or our SearMagic grids.



1 STAINLESS STEEL COOKING GRIDS

Commercial Grade Stainless Steel Cooking grids have 5/16" thick rods to accommodate small items.

2 FLAVOR PLATES

These 14-gauge stainless steel, self-cleaning plates distribute heat evenly over the entire grilling surface and produce barbecue flavor while reducing flare-ups.

3 TRADITIONAL BURNER

Quality commercial grade 16-gauge stainless steel burners.



Hybrid Burners



Briquette Burner System

SEARMAGIC COOKING GRIDS

These high-performance, reversible, rust-free, hard-coat anodized aluminum cooking grids heat up faster and cook foods at a uniform temperature. The ribbed side is perfect for steaks and burgers while the smooth side is ideal for delicate items such as fish or vegetables.

All grill models are available with or without this feature



Ribbed Side



Smooth Side

PROFIRE GRILL LIDS

Two layers of heavy-duty stainless steel to prevent heat loss and keep the outer lid cooler. Seamless lids are accented with a polished mirror finish.



REAR INFRARED BURNER

Heats up fast to quickly put a seal around meats for juicier and more moist results. Comes with a heavy-duty rotisserie.

All grill models are available with or without this feature.



ELECTRONIC MULTIPLE SPARK IGNITION

Allows for quick, easy and reliable starts.

**Traditional Burners
PROFESSIONAL
PF SERIES
Grill Heads**



**CUT-OUT
DIMENSIONS**
48-1/4" W
10" H
24-1/2" D



**CUT-OUT
DIMENSIONS**
48-1/4" W
10" H
24-1/2" D

	PF48R	PF48G	PF48RS	PF48S
Cooking Area	966 Sq. In.	966 Sq. In.	714 Sq. In.	714 Sq. In.
BTU's	88,000	88,000	66,000	66,000
# of 11,000 BTU Burners (Traditional)	8	8	6	6
# of Controlled Cooking Zones	4	4	3	3
Infrared Rear Burner BTU's	13,500	—	11,500	—
Heavy-Duty Rotisserie	✓	—	✓	—
Integrated Side Burner	—	—	Double	Double
Integrated Side Burner BTU's	—	—	30,000	30,000
Stainless Steel Cooking Grids	Standard	Standard	Standard	Standard
SearMagic Cooking Grids	PFSM48R	PFSM48G	PFSM48RS	PFSM48S

**Traditional Burners
PROFESSIONAL
PF SERIES
Grill Heads**



**CUT-OUT
DIMENSIONS**
36-1/4" W
10" H
24-1/2" D



**CUT-OUT
DIMENSIONS**
27-1/4" W
10" H
24-1/2" D

	PF36R	PF36G	PF27R	PF27G
Cooking Area	714 Sq. In.	714 Sq. In.	525 Sq. In.	525 Sq. In.
BTU's	66,000	66,000	44,000	44,000
# of 11,000 BTU Burners (Traditional)	6	6	4	4
# of Controlled Cooking Zones	3	3	2	2
Infrared Rear Burner BTU's	11,500	11,500	11,500	—
Heavy-Duty Rotisserie	✓	—	✓	—
Stainless Steel Cooking Grids	Standard	Standard	Standard	Standard
SearMagic Cooking Grids	PFSM36R	PFSM36G	PFSM27R	PFSM27G

MOUNTING & DESIGN OPTIONS

We have a variety of options to create your ideal outdoor entertainment area.

Briquette System PROFESSIONAL PF SERIES Grill Heads



**CUT-OUT
DIMENSIONS**
48-1/4" W
10" H
24-1/2" D



**CUT-OUT
DIMENSIONS**
48-1/4" W
10" H
24-1/2" D

	BQPF48R	BQPF48RIH	BQPF48G	BQPF48GIH	BQPF48RS	BQPF48RSIH	BQPF48S	BQPF48SIH
Cooking Area	966 Sq. In.	966 Sq. In.	966 Sq. In.	966 Sq. In.	714 Sq. In.	714 Sq. In.	714 Sq. In.	714 Sq. In.
BTU's	88,000	98,000	88,000	98,000	66,000	76,000	66,000	76,000
# of 11,000 BTU Burners (Traditional)	8	6	8	6	6	4	6	4
# of 32,000 BTU Burners (Infrared)	—	1	—	1	—	1	—	1
# of Controlled Cooking Zones	4	4	4	4	3	3	3	3
Infrared Rear Burner BTU's	13,500	13,500	—	—	11,500	11,500	—	—
Heavy-Duty Rotisserie	✓	✓	—	—	✓	✓	—	—
Integrated Side Burner	—	—	—	—	Double	Double	Double	Double
Integrated Side Burner BTU's	—	—	—	—	30,000	30,000	30,000	30,000
Stainless Steel Cooking Grids	Standard	Standard	Standard	Standard	Standard	Standard	Standard	Standard
SearMagic Cooking Grids	PFSM48R	—	PFSM48G	—	PFSM48RS	—	PFSM48S	—

Briquette System PROFESSIONAL PF SERIES Grill Heads



**CUT-OUT
DIMENSIONS**
36-1/4" W
10" H
24-1/2" D



**CUT-OUT
DIMENSIONS**
27-1/4" W
10" H
24-1/2" D

	BQPF36R	BQPF36RIH	BQPF36G	BQPF36GIH	BQPF27R	BQPF27RIH	BQPF27G	BQPF27GIH
Cooking Area	714 Sq. In.	714 Sq. In.	714 Sq. In.	714 Sq. In.	525 Sq. In.	525 Sq. In.	525 Sq. In.	525 Sq. In.
BTU's	66,000	76,000	66,000	76,000	44,000	54,000	44,000	54,000
# of 11,000 BTU Burners (Traditional)	6	4	6	4	4	2	4	2
# of 32,000 BTU Burners (Infrared)	—	1	—	1	—	1	—	1
# of Controlled Cooking Zones	3	3	3	3	2	2	2	2
Infrared Rear Burner BTU's	11,500	11,500	—	—	11,500	11,500	—	—
Heavy-Duty Rotisserie	✓	✓	—	—	✓	✓	—	—
Stainless Steel Cooking Grids	Standard	Standard	Standard	Standard	Standard	Standard	Standard	Standard
SearMagic Cooking Grids	PFSM36R	—	PFSM36G	—	PFSM27R	—	PFSM27G	—

MOUNTING & DESIGN OPTIONS

We have a variety of options to create your ideal outdoor entertainment area.

Hybrid Burners
**PROFESSIONAL
PF SERIES**
Grill Heads



**CUT-OUT
DIMENSIONS**
48-1/4" W
10" H
24-1/2" D



**CUT-OUT
DIMENSIONS**
48-1/4" W
10" H
24-1/2" D

	PF48RIH	PF48GIH	PF48RSIH	PF48SIH
Cooking Area	966 Sq. In.	966 Sq. In.	714 Sq. In.	714 Sq. In.
BTU's	98,000	98,000	76,000	76,000
# of 11,000 BTU Burners (Traditional)	6	6	4	4
# of 32,000 BTU Burners (Infrared)	1	1	1	1
# of Controlled Cooking Zones	4	4	3	3
Infrared Rear Burner BTU's	13,500	—	11,500	—
Heavy-Duty Rotisserie	✓	—	✓	—
Integrated Side Burner	—	—	Double	Double
Integrated Side Burner BTU's	—	—	30,000	30,000
Stainless Steel Cooking Grids	Standard	Standard	Standard	Standard

Hybrid Burners
**PROFESSIONAL
PF SERIES**
Grill Heads



**CUT-OUT
DIMENSIONS**
36-1/4" W
10" H
24-1/2" D



**CUT-OUT
DIMENSIONS**
27-1/4" W
10" H
24-1/2" D

	P36RIH	PF36GIH	PF27RIH	PF27GIH
Cooking Area	714 Sq. In.	714 Sq. In.	525 Sq. In.	525 Sq. In.
BTU's	76,000	66,000	54,000	54,000
# of 11,000 BTU Burners (Traditional)	4	4	2	2
# of 32,000 BTU Burners (Infrared)	1	1	1	1
# of Controlled Cooking Zones	3	3	2	2
Infrared Rear Burner BTU's	11,500	—	11,500	—
Heavy-Duty Rotisserie	✓	—	✓	—
Stainless Steel Cooking Grids	Standard	Standard	Standard	Standard

MOUNTING & DESIGN OPTIONS

We have a variety of options to create your ideal outdoor entertainment area.



PF48SSCBN Cart Shown with a PF48RS Grill Head

Made in America

Professional PF & PFDLX Series Grill Carts

These stainless steel American-made grill carts are stylish, durable and perfectly designed to pair with our ProFire Grill Heads. The **Professional PF** and **PFDLX Series** feature two drop-down stainless steel side shelves and are available in three sizes—48", 36" and 27". All carts are available for both LP Gas and Natural Gas applications.

PROFESSIONAL PF & PFDLX SERIES GRILL CARTS



	PF27SSCBN PF27SSCBP		PF36SSCBN PF36SSCBP		PF48SSCBN PF48SSCBP	
Stainless Steel Construction	✓ *Limited Lifetime Warranty		✓ *Limited Lifetime Warranty		✓ *Limited Lifetime Warranty	
Stainless Steel Fold-Down Side Shelves	✓ Two Drop-Down Shelves		✓ Two Drop-Down Shelves		✓ Two Drop-Down Shelves	
Double-Lined Stainless Steel Doors	✓ Two Doors		✓ Two Doors		✓ Three Doors	
Four Commercial-Grade Casters	✓ Two Locking Casters		✓ Two Locking Casters		✓ Two Locking Casters	
Available for Natural Gas	✓	—	✓	—	✓	—
Available for Propane Gas	—	✓	—	✓	—	✓
Natural Gas Quick Disconnect Hose (for natural gas models only)	12 Ft. Hose	—	12 Ft. Hose	—	12 Ft. Hose	—
LP Tank Slide-Out Drawer (for LP gas models only)	—	—	—	✓	—	✓

LP TANK SLIDE-OUT DRAWER

Swapping out LP Tanks is made easy with the LP Tank Slide-Out Drawer—included on the PF36SSCBP & PF48SSCBP models.



GRILL COVERS | For Cart Models



- PFVC26C**
Fits 26" Cart Model Grill

- PFVC27C**
Fits 27" Cart Model Grill

- PFVC33C**
Fits 33" Cart Model Grill

- PFVC36C**
Fits 36" Cart Model Grill

- PFVC48C**
Fits 48" Cart Model Grill

- PFVC48CS**
Fits 36" Cart Model Grill with Side Burner

ROTISSERIES



Heavy-Duty Rotisserie

- PFR27**
27" Grill | 25 lb capacity

- PFR30**
26" Grill | 25 lb capacity

- PFR33**
33" Grill | 25 lb capacity



Super Heavy-Duty Rotisserie

- PFR27HD**
27" Grill | 50 lb capacity

- PFR36HD**
36" Grill | 25 lb capacity

- PFR36HD**
48" Grill | 25 lb capacity

WARMING RACKS



- PF27WRM**
PF Series | 27" Grills

- PF30WRM**
LX & PERF Series | 26" LX/30" PERF Grills

- PF30WRM**
LX & PERF Series | 26" LX/30" PERF Grills

- PF30WRM**
LX & PERF Series | 26" LX/30" PERF Grills

- PF30WRM**
LX & PERF Series | 26" LX/30" PERF Grills

GRIDDLES



- PFGRIDL26**
Fits 26" and 43" Model Grill

- PFGRIDL27**
Fits 27" Model Grill



- PFGRIDL36**
Fits 36" or 48" Model Grill

PFFRIG24
Outdoor Refrigerator

24" Built-In or Portable Outdoor-Rated Stainless Steel Refrigerator with Glass Door

- Stainless steel construction inside & out *304 commercial-grade stainless steel*
- Fully integrated locking glass door
- 5 Cu. Ft. *Plenty of room for food and beverages*
- Touchpad variable temperature control with LED display *Adjust temperature with the touch of a button*
- Designed for built-in or free-standing applications
- Reversible door swing *Door can be easily converted to open right or left*
- Three adjustable black wire shelves

- Adjustable leveling legs
- ETL approved for outdoor use
- Front venting
- LED interior lighting
- Easy to Clean
- Quiet, efficient operation

-  **LIMITED LIFETIME WARRANTY (Against Rust Through)**
Stainless Steel Exterior Body • Stainless Steel Interior Liner
-  **3-YEAR WARRANTY**
Compressor System
-  **1-YEAR WARRANTY**
All remaining parts with the exception of normal wear parts like filters & light bulbs





Create an entertainment area perfectly suited to your space and needs.

All of our options are specifically built to enhance your grilling experience and feature the same level of craftsmanship that we put into our grills. Made in the USA and constructed of heavy-duty 14-, 16- and 18-gauge commercial stainless steel and covered by a Limited Lifetime Warranty*.



A Insulated Sleeve

When installing the grill into an island made of combustible materials, an insulated sleeve is required

B Large Double Doors

Provides ample storage space that is both convenient and easy to access.

C Counter Trim Kit

Creates a finished look for mounted grills and sideburners

D Side Burner

Additional cooking surface for more grilling versatility

E Small Double Doors

Access to storage space available in a variety of sizes to fit your specific needs

F Triple Drawer

Perfect place to store grilling utensils, accessories and more

** Against Rust Through*

BUILT-IN SIDEBURNERS



**Double Side Burner
PFDLXDSB**



**Double Side Burner
PFDSB**

Overall Dimensions	12-1/2" W x 10" H x 24-1/2" D	12-1/2" W x 10" H x 24-1/2" D
Opening Needed	13" W x 10" H x 24-1/2" D	13" W x 10" H x 24-1/2" D
BTUs	30,000	30,000
Use Trim Kit	PFTRIMDS	PFTRIMDS
Use Insulated Sleeve	PFISDSB	PFISDSB



**Single Side Burner
PFSSB**

Overall Dimensions	12-1/2" W x 10" H x 14-1/4" D
Opening Needed	13" W x 10" H x 14-1/4" D
BTUs	15,000
Use Trim Kit	PFTRIMSS
Use Insulated Sleeve	PFISDSB

INSULATED SLEEVES (for side burners)



PFISSSB | Single Side Burner
15-3/4" W x 11-1/8" H x 14" D

PFISDSB | Double Side Burner
15-3/4" W x 11-1/8" H x 24-1/2" D



TRIM KITS (for side burners)







PFTRIMSS | Single Side Burner
15-3/4" W x 11-1/8" H x 14" D

PFTRIMDS | Double Side Burner
15-3/4" W x 11-1/8" H x 24-1/2" D





ACCESS DOORS

				
	Extra Large Double Doors PFDD48	Tall Extra Large Double Doors PFDD48-T	Large Double Doors PFDD	Tall Large Double Doors PFDD-T
Overall Dimensions	47" W x 19" H	47" W x 23" H	35" W x 19" H	35" W x 23" H
Opening Needed	44-1/4" W x 16-1/4" H	44-1/4" W x 20" H	32-1/4" W x 16-1/4" H	32-1/4" x 20" H
Opening Direction	—	—	—	—

				
	Small Double Doors PFSMDD	Tall Small Double Doors PFSMDD-T	Horizontal Single Door PFSD2014R PFSD2014L	Small Vertical Single Door PFSD1420R PFSD1420L
Overall Dimensions	30" W x 19" H	30" W x 23" H	24" W x 18" H	18" W x 24" H
Opening Needed	27-1/4" W x 16-1/4" H	27-1/4" W x 20" H	20-1/4" W x 14-1/4" H	14-1/4" W x 20-1/4" H
Opening Direction	—	—	Right or Left	Right or Left

		
	Large Vertical Single Door PFLGDOORR PFLGDOORL	Door & Drawer Combo PFDOOR/DRW
Overall Dimensions	17" W x 28" H	17" W x 28" H
Opening Needed	14-1/2" W x 25-1/2" H	14-1/2" W x 25-1/2" H
Opening Direction	Right or Left	Right

DRAWERS

				
	Single Drawer PFSGLDRW	Double Drawer PFDBLDRW	Triple Drawer PFTRPDRW	Pull-Out Trash Compartment PFPULLOUT
Overall Dimensions	17" W x 9" H x 21" D	17" W x 17" H x 21" D	16" W x 28" H x 21" D	17" W x 28" H x 18-1/2" D
Opening Needed	14-1/2" W x 6-1/2"	14-1/2" W x 14-1/2" H	14-1/2" W x 25-1/2" H	14-1/2" W x 25-1/2" H

COOLERS



Cocktail Pro
PFCKTPRO

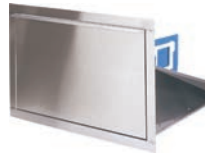

Cooler Pull-Out
PFCOOLER

Overall Dimensions	19" W x 10" H x 24-1/2" D	30" W x 20" H x 20-1/2" D
Opening Needed	19-1/4" W x 10" H x 24-1/2" D	27-1/2" W x 17-1/2" H

BUILT-IN GRILL COVERS



PART #	FITS
PFVC27B	27" Built-In Model Grills
PFVC30B	PERF30 & 26" LX Built-In Model Grills
PFVC33B	33" LX Built-In Model Grills
PFVC36B	36" Built-In Model Grills
PFVC42B	42" Built-In Model Grills
PFVC48B	48" Built-In Model Grills
PFVC48BS	36" Built-In Model Grill with Side Burner

INSULATED SLEEVES



PFIS27 | 27" grill
30" W x 11-1/8" H x 24-1/2" D

PFIS36 | 36" grill
39" W x 11-1/8" H x 24-1/2" D

PFIS48 | 48" grill
51" W x 11-1/8" H x 24-1/2" D

TRIM KITS



PFTRIM27 | 27" grill
27-1/2" W x 10" H x 24-1/2" D

PRTRIM36 | 36" grill
36-1/2" W x 10" H x 24-1/2" D

PFTRIM48 | 48" grill
48-1/2" W x 10" H x 24-1/2" D

ProSear Infrared Indoor Grill



Cabinetry not included



Our US Made, Infrared stainless steel constructed ProSear Indoor Grill is the first and only of its kind on the market today.

Features:

- Stainless steel construction
- Electronic ignition, 120 volt operation automatically ignites burners
- 5/16" stainless steel rods cooking grids
- 35,000 BTU rated per-hour input
- 333 square inches total cooking area
- Limited lifetime warranty (on rust-through) on stainless steel cooking grids and stainless steel body components. 5 year warranty on infrared components and 1 year warranty on all other components.
- Stainless steel dust cover included
- Available for Natural or LP Gas application

Advantages of Infrared Burner Technology:

- Fast...heats up in approximately 5 minutes
- Intense heat-seals in meat juices for better flavor
- Time saver...heats up faster with shorter grilling time
- High intense heat reduces flare-ups by vaporizing juices instantly

PFINDOOR-N

30" NG Stainless Steel
Indoor Infrared Gas Grill

PFINDOOR-P

30" LP Stainless Steel
Indoor Infrared Gas Grill

MODEL	POWER REQUIREMENTS	VENT HOOD REQUIREMENTS	VENT HOOD CLEARANCE	OVERALL DIMENSIONS	CUT-OUT DIMENSIONS	WEIGHT
PFINDOOR	120 Volts, 60H, 0.12 AMP	<ul style="list-style-type: none"> • 36" Minimum Vent Hood • 600 CFM Internal Blower • 900 CFM External Blower 	From cooking surface to vent hood Minimum - 26" Maximum - 30"	30-1/2" W x 21" L x 12-3/4"D	29" (left to right) X 20" (front to back)	128 lbs.

Clearances:

Side Wall/Alcove Counter Installations, with heat shield installed, shall have minimum horizontal distance(s) from the sides and back of appliance to adjacent vertical combustible walls extending above the top panel, 6 inches from the side walls, 4 inches from the rear wall. Minimum horizontal distance from the front edge of the counter to the front side of the appliance, 1 inch. Minimum vertical distance from the top of the cooking grid to an overhead unprotected combustible surface is 48". Maximum depth of the overhead cabinets is 13 inches.

Island Counter Installation, without heat shield installed, shall have minimum horizontal distance(s) from the sides and back of appliance to adjacent vertical combustible walls extending above the top panel, 14 inches from the side walls, 14 inches from the rear wall. Minimum horizontal distance from the front edge of the counter to the front side of the appliance, 1 inch.

Zero to combustibles below cooking surface

ProFire Grill Warranty



ProFire, LLC hereby warrants to the Original Purchaser of the ProFire Gas Grill that it will be free of defects in material and workmanship from the date of purchase as follows:



PROFESSIONAL & DELUXE SERIES MODELS LIMITED LIFETIME WARRANTY:

(Against Rust Through)

- Stainless Steel Body
- Stainless Steel Hoods & Liners
- Stainless Steel Lids
- Stainless Steel Drip Pans
- Gas Manifolds
- Stainless Steel Carts & Shelves
- Stainless Steel Heat Plates
- Stainless Steel Burners
- Cooking Grids & Warming Racks
- Gas Valves



5-YEAR WARRANTY ON THE FOLLOWING:

- Infrared Burners



2-YEAR WARRANTY ON THE FOLLOWING:

- Cast Iron Burners
- Lights & Electronics
- All Other Components

**PROFIRE GRILLS
HAS THE MOST
COMPREHENSIVE
LIFETIME WARRANTY
IN THE INDUSTRY**

Backed by MHP, the company that started it all, with over 60 years of proven quality and friendly knowledgeable service. Our Lifetime Warranty actually means something.

Simply Put...
The ProFire Grill Warranty
Exceeds the Competition

When assembled and operated in accordance with the printed instructions accompanying it. ProFire requires reasonable proof of your date of purchase. **Therefore, you must retain your sales slip or invoice. Grill must be registered within 60 days of purchase for warranty to be valid. This warranty is in effect for all grills purchased after April 1, 2018.**

Grills in a commercial, community or multi-tenant application will have a 1 year warranty on all parts.

ProSear Infrared Indoor Grill Warranty



LIMITED LIFETIME

- Stainless Steel Cooking Grid
- Stainless Steel Body



5-YEAR WARRANTY

- Infrared Burner



1 YEAR WARRANTY:

- All Other Grill Components

Grills in a commercial, community or multi-tenant application will have a 1 year warranty on all parts.

For full warranty disclosure please visit, mhpgrills.com



California Proposition 65 Warning: This product can expose you to chemicals including Chromium (hexavalent compounds), which are known to the State of California to cause cancer and birth defects or other reproductive harm. For more information go to: www.P65Warnings.ca.gov.





We have owned our ProFire Grill for the past 15 years and have grilled everything from burgers and steaks to fish and vegetables. It is one of the best investments we have made for our outdoor patio living space.

JIM, WISCONSIN

Modern Home Products

Providing outstanding products and service for over 60 years!

A complete line of grills, accessories, lighting and replacement parts backed by quality, innovation and reliability

PROFIRE GRILLS

A DIVISION OF MODERN HOME PRODUCTS CORPORATION

5565 North 124th Street • Butler, WI 53007

www.mhpgrills.com

262.781.4657

888.781.4657

YOUR LOCAL DEALER:

