

MHP
OUTDOOR GRILLS

Sear Magic®
Patented
Infrared Side Grill

Assembly and Maintenance Instructions



**THIS GAS APPLIANCE IS
DESIGNED FOR OUTDOOR
USE ONLY.**

⚠ FOR YOUR SAFETY

If you smell gas:

1. Shut off gas to appliance.
2. Extinguish any open flame.
3. Open Lid.
4. If odor continues, immediately call your gas supplier or your fire department.

⚠ FOR YOUR SAFETY

1. Do not store or use gasoline or other flammable vapors and liquids in the vicinity of this or any other appliance.
2. An LP cylinder not connected for use shall not be stored in the vicinity of this or any other appliance.

⚠ FOR YOUR SAFETY

Follow all leak-test procedures carefully in this manual before using. Do this even if the grill was dealer assembled. Do not try to light this appliance without reading the "Lighting" instructions in this manual.

Pros of SearMagic Infrared Side Grill

- Uniform Heating Surface
- High Temperature Option
- Energy Efficiency
- Extremely Hot, Sealing in Meat Juices
- Tasty and Juicy Food



**YOU MUST READ THIS OWNERS MANUAL
BEFORE OPERATING YOUR GAS GRILL.**

**THESE INSTRUCTIONS SHOULD BE LEFT
WITH THE CUSTOMER. KEEP THESE IN-
STRUCTIONS FOR FUTURE REFERENCE.**

"California Proposition 65 Warning"
Chemicals known to the State of California to cause cancer and birth defects or other reproductive harm are created by the combustion of propane, charcoal, wood products or natural gas used with this grill and in the preparation of grilled foods.

Congratulations on your purchase of MHP SearMagic Infrared Zone, providing your MHP Grill with greater versatility. This unique searing system gets hot extremely fast sealing in meat juices quickly without drying out. Meat juices will be sealed inside keeping the chicken, steak or additional cut of meat juicy and tender. The high intense heat reduces flare-ups by vaporizing juices instantly. Also, with the fast heat-up and faster cooking, makes your MHP SearMagic Infrared Zone more energy efficient.

Caution: Before Starting To Assembly Your SearMagic Infrared Zone. Be sure the gas supply is turned off. Turn grill to "OFF". Close Valve on LP Tank and disconnect the hose/regulator assembly from tank. OR, if your grill is a natural gas unit; close valve on main gas supply going to the grill.

Getting to Know Your SearMagic Infrared Zone and Assembly

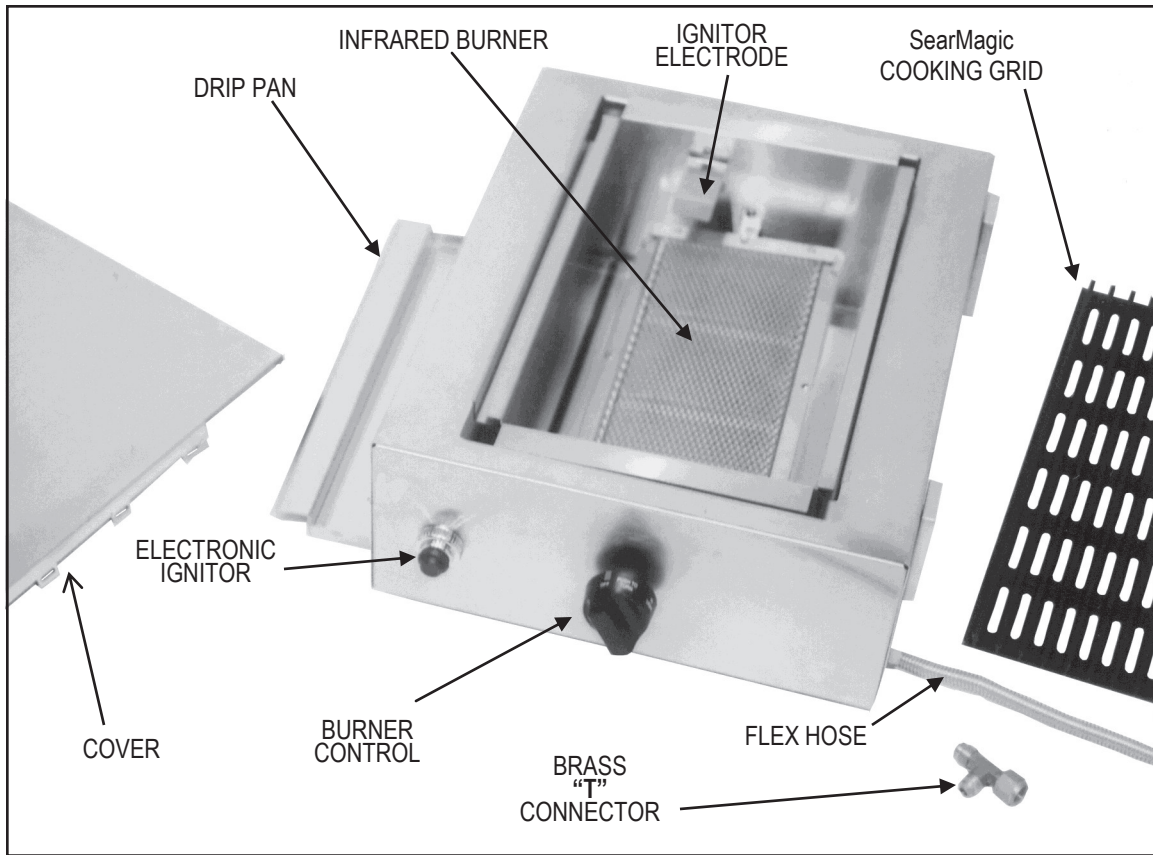

SearMagic Infrared Side Grill Assembly Hardware

| | |
|---|----------------------------|
| 2 | 1/4" x 20 Kep Nuts |
| 2 | 1/4" x 20 x 3/4" Hex Bolts |

1. If your grill has two (2) shelves, remove the left shelf from the grill bottom (facing the grill).
2. Open Grill Lid and insert screw 1/4-20 x 1 1/2" hex bolts in the two (2) upper casting holes. (Fig. 1)
3. Secure SearMagic Burner mounting bracket (Fig. 2) on extended hex bolts in (Fig. 1) and secure with Kep Nuts (Fig. 3)

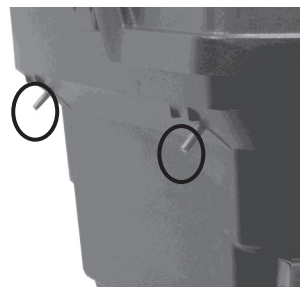

(Fig. 1)

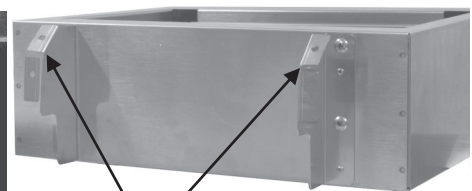

(Fig. 2) Mounting Holes

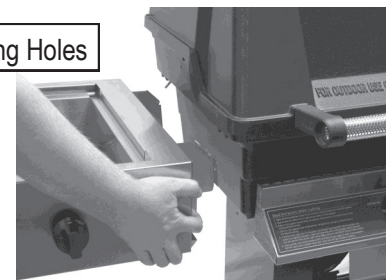

(Fig. 3)

Changing Valve Connector

IMPORTANT: Be Sure Gas Supply Is "OFF" Before Starting.

1. If your grill head is mounted on a column, the access panel must be removed to expose the valve. (Fig. 3)

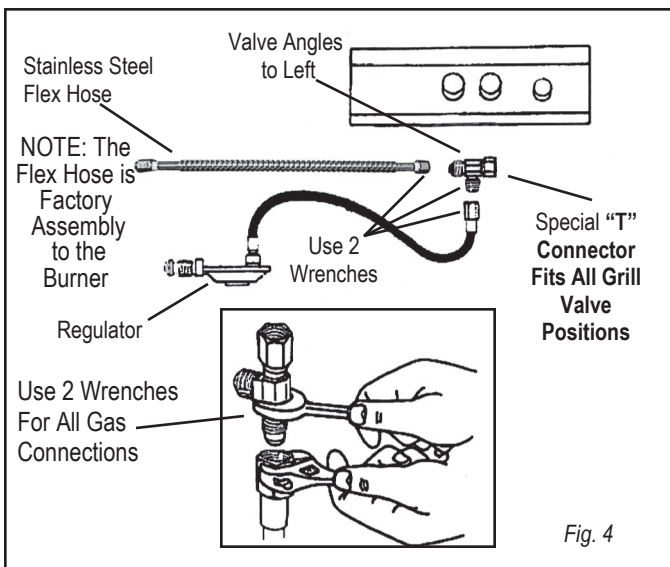
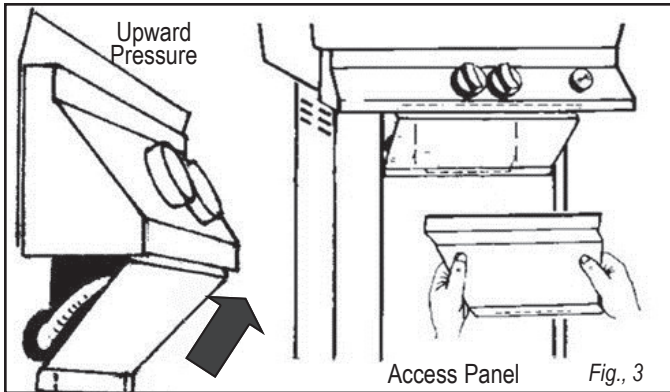

2. Loosen and remove the gas supply hose to the grill valve (in the center of the control panel). Attach the special "T" connector to the grill valve in the position shown then reattach the gas supply hose to the "T" connector. Tighten securely using two wrenches. Fig. 4
3. **CAUTION: The system must be checked for leaks. Check all connections with 50/50 solution of detergent and water to see where bubbles appear. Retighten the connections.**

SearMagic Infrared Side Grill Cover

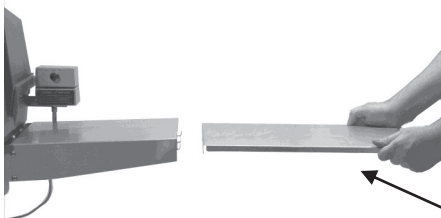

When Burner is in Use, Remove and Hang on the Right

Infrared Burner Lighting Instructions

1. Always remove the cover before lighting.
2. Keep your head and body at least 1 foot away when lighting the burner. Do not lean over an open burner.
3. Turn the burner on the "HIGH" position, and depress the electronic ignitor until the burner lights.
4. If the burner fails to light, turn control knob "OFF", wait 5 minutes for gas to clear and try lighting again.
5. If the ignitor doesn't spark, check the gap between the wire probe burner screen. It should be approximately 3/16 inches wide. If it is too small, the spark may be inefficient. Gently readjust the wire probe as needed. If the gap is normal, check the wire connections at the spark module and ignitor probes, located underneath the control panel.
6. If the ignitor still doesn't work, try replacing the battery. Remove the collar around the ignitor button by turning it counter-clockwise. Replace the AAA battery, "+" side down. Fig. 5
7. In the unlikely event these previous measures don't work, you can light the burner manually. Turn the burner control knob to "OFF". Remove the cooking grid from above the burner and ignite a match. Place the match directly on the burner screen, remove your hand from above the burner and turn the burner control knob on "HIGH". Once the burner is lit, you can replace the cooking grid.

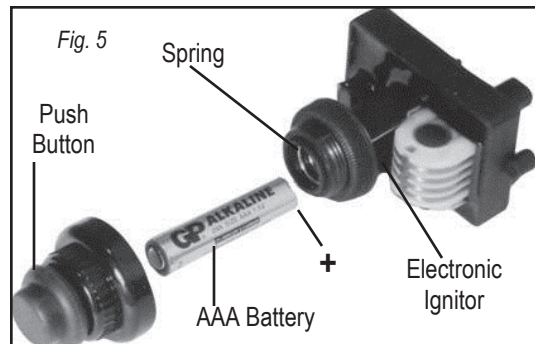

Infrared Care and Maintenance

1. After each use, remove the cover and light the burner on "HIGH" and burner for 5 minutes. This will burn off any food drippings and enhance the burner performance and increase the burner longevity.
2. Never use water or liquid chemicals to clean the ceramic burner. Burner may be damaged. **Burner failure caused by improper care and maintenance is not covered under warranty.**
3. If the burner develops ash over the surface, clean it gently with a vacuum cleaner. Use a brush attachment so as not to damage the burner.
4. If the burner should get wet, it is important to dry it out completely before attempting to use the burner. **IMPORTANT: Replace Cover When Burner Is Not In Use.**
5. Never let anything heavy, hard or sharp fall onto the burner. The ceramic is very fragile and can easily be damaged.

Infrared Cooking Tips.

1. Infrared burners get very hot. **Do not leave food unattended on the grill for any length of time.**
2. Estimate cooking times to be 30% to 50% less than a conventional grill.
3. Always thaw food thoroughly before cooking to achieve better, more predictable results.
4. Always use long handled grill tools for grilling. A grilling mitt may be useful for handling hot items.
5. The use of a fork is not recommended for grilling on your new SearMagic Infrared Zone. A fork may mar the surface of the cooking grid. Piercing foods while cooking will allow the juices to escape, causing the finished product to be drier than may be desired.
6. To minimize flare-up, trim fat from meats or remove skin from poultry.
7. If a flare-up occurs, don't try to control it with water. Water can cause burner damage. Instead, move the food to another part of the cooking grid, lower the heat setting or remove the food. **Burner Failure Caused By Water Damage Is Not Covered Under Warranty.**
8. Allow the burner to heat up for 5 minutes on "HIGH" before cooking.
9. Place the food on the SearMagic cooking grid while the grill is on "HIGH" to sear the food thoroughly. Searing is the key to locking in the juices for that delicious grilled flavor.
10. After searing for 2-3 minutes per side, lower the temperature to finish cooking the food as desired.
11. The SearMagic cooking grid allow for greater versatility when grilling. Chicken breasts, steaks, pork chops or hamburgers can be seared over the ribbed side at a higher temperature. Delicate foods like seafood and vegetables can cooked over a lower temperature with the smooth side up.
12. To clean the SearMagic Infrared Zone after cooking, burn at "HIGH" for at least 5 minutes. With the grill still on "HIGH", clean the cooking grid with a long-handled brass bristle brush. Regular cleaning will ensure optimum performance of your SearMagic Infrared Side Grill.

WARRANTY

| | |
|---------------------------|-------------------------------------|
| LIFETIME WARRANTY: | SearMagic Cooking Grid |
| 10-Year Warranty: | Stainless Steel Enclosure and Cover |
| 5-Year Warranty: | Infrared Burner |
| 1-Year Warranty: | Igniter System • Gas Valve |

WHAT IS NOT COVERED:

- Transportation and shipping costs.
- Labor for replacement or repairs.
- Damage from accident, misuse, alteration, abuse, improper installation or storage.
- Removal and reinstallation cost.
- Finishes on surfaces that are damaged by improper installation, improper storage, accident, misuse, abuse or alteration.
- Inoperable due to improper installation or storage.
- The costs of a service call to diagnose a problem.
- All warranties are non-transferable and apply only to the original purchaser.
- Warranties are null and void if SearMagic Infrared Zone is put into commercial or community use.

This warranty does not imply or assume any responsibility for consequential damages that might result from use, misuse, or improper installation of this cooking appliance. This warranty does not cover claims which do not involve defective workmanship or materials. A bill of sale, cancelled check, or payment record should be kept to verify purchase date and establish warranty period.



MHP
OUTDOOR GRILLS

150 S. Ram Road • Antioch • IL • 60002
Phone: 847.395.6556 • 800.647.4745
Fax: 847.395.9121
Email: info@mhpgrills.com
Web Site: www.mhpgrills.com

Other Quality Products From Modern Home Products

ProFire® Grills
Perfection by Design

PHOENIX
GRILLS

MHP
GRILL PARTS

Everglow
GAS LAMPS & TORCHES